

PB • PALLET BLOCKS • PELLETS • WASTE • LIME



## SINGLE-ROTOR PRE-CRUSHERS

### **ALLIGATOR**

FROM URBAN FOREST TO PRE-CRUSHED MATERIAL

#### **TECHNICAL FEATURES**

- Very large feeding hopper for bulky material
- Low-speed crushing rotor equipped with strong teeth
- Hydraulic drive protected from overloads
- Discharge sizing screen for pre-crushed material.

#### **BENEFITS**

- Drastic volume reduction of bulky recycling, i.e. from 60-80 to 130-150 kg/m<sup>3</sup> bd
- Easier & cheaper transportation of pre-crushed material
- Full protection from overloads, e.g. from foreign bodies
- Compact, simple, versatile, highly reliable and efficient system
- Minimum noise
- Very low maintenance
- Low energy consumption.

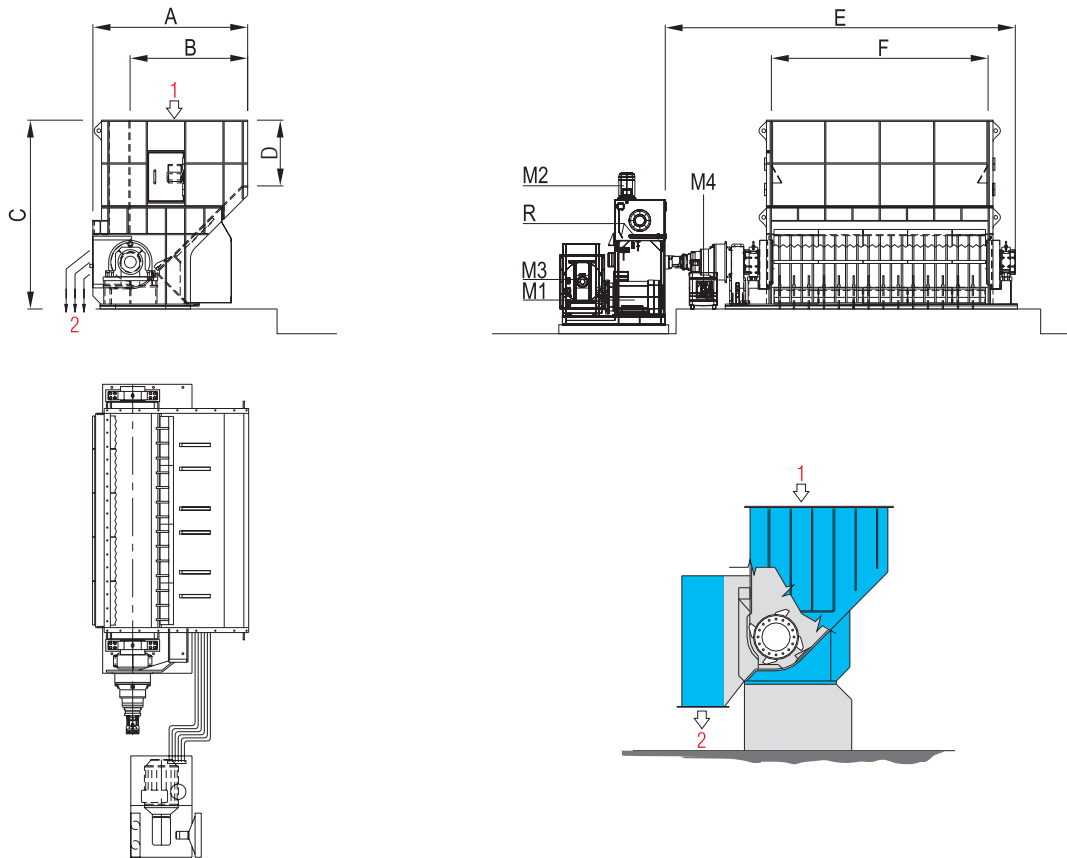

1= INFEED  
2= OUTFEED

M1= MAIN MOTOR  
M2= FEEDING HYDRAULIC UNIT

M3= HEAT EXCHANGER FOR OIL  
M4= HEAT EXCHANGER FOR GEAR BOX

R= RESISTORS FOR HEATING OIL

MODEL	OVERALL DIMENSIONS mm					
	A	B	C	D	E	F
<b>ALLIGATOR 80-350/240</b>	2500	1900	3050	1060	5720	3500

\*Open side for feeding

MODEL	CAPACITY** t/h	INSTALLED POWER kW					WEIGHT APPROX. kg
		M1	M2	M3	M4	R***	
<b>ALLIGATOR 80-350/240</b>	15-25	75-90	7,50	1,10	0,75	3 x 2	22000

\*\*According to type-volume of material and infeed efficiency \*\*Resistors for heating oil - option