

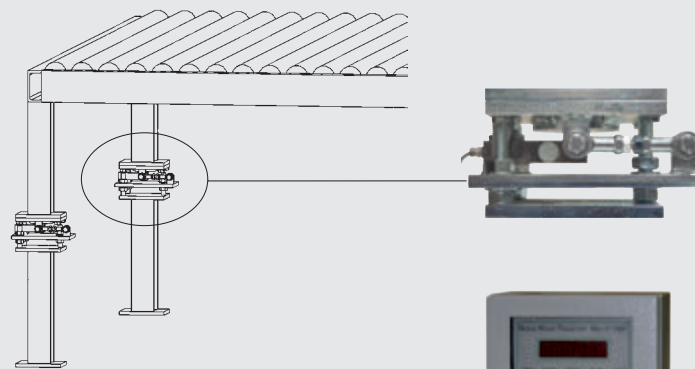

• PB • OSB • MDF

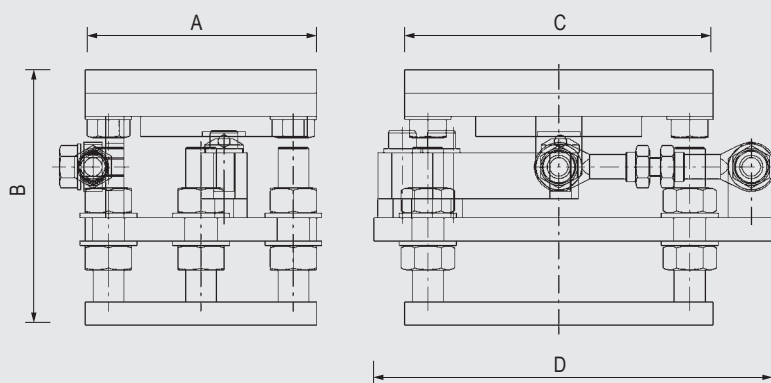

DIGITAL WEIGHT AMPLIFIER



RAW BOARD SCALE

BPP

CONTINUOUS RAW BOARD SCALE

This weighing system is composed of load cells, of a suitable load, to support the conveyor unit.

An IMAL electronic digital amplifier supplies the voltage, appropriately filtered and adjusted, to the cells, and amplifies the proportional weight signal. This value can then be transmitted to other quality control systems, like the thickness gauge, so that density may be calculated.

The integrated display and keyboard are used to programme the software processing parameters, especially with regard to the tare and full scale values.

MAIN FEATURES

- Digital signal processing • Highly accurate • Non-stop board weighing • Possibility of linking up with other systems
- Simple to install.

MODEL	OVERALL DIMENSIONS mm			
	A	B	C	D
BPP	150	165	200	260

Not binding data. IMAL-PAL Group reserves the right to make any modifications to the contents herein without prior notice. We kindly ask you to contact our technical department for eventual updates on the information provided.

Rev.07 dated 05/2015

