



• PB • OSB



GLUE BLENDER

IPL

LOW SPEED, LONG MIXING, HIGH-TECH GLUING PROCESS

IPL blenders have long chambers for low speed and long blending of particles and resin. This reduces the breakage of the large particles, minimizes the centrifugation of the fines and distributes the glue over all the fractions in a much more uniform and even manner. The optional Microcomp CGDW, blender mixing time control unit, enables a good quality and constant blend to be achieved by adjusting the discharge gate.

MAIN FEATURES

- Soft mixing prevents breakage of the larger particles
- Low speed reduces blender chamber wear
- Accurately balanced to eliminate vibration
- Resin distributed evenly over all the particle fractions
- Blending time constantly controlled by the Microcomp CGDW (optional)
- All the mixing chambers are made of special wear resistant steel (Avesta 2205)
- The new sprayer nozzles remain clean for a very long time
- The mixing chamber and discharge hatch are water cooled
- Motorized lid to open and close the blender.

OPTIONS

- **MICROCOMP CGDW:** Microprocessor blender mixing time control unit
- **PANZER:** Tungsten carbide coated wear resistant chamber for gluing even the most abrasive particles
- **S:** Maintenance switch for the main motor, as per EC standards
- **P:** Pre wiring in an on-board panel
- **INJ:** Dust injection system
- **ATEX:** Equipment compliant with 94/9/CE/ATEX 95 Directive and suitable for zone 22 installation (on the basis of Directive 99/92/CE ATEX 137), and that is, intended for use in potentially explosive atmospheres due to the presence of dust.

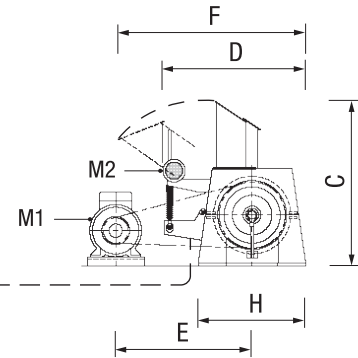
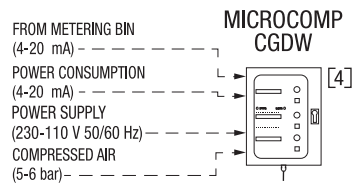
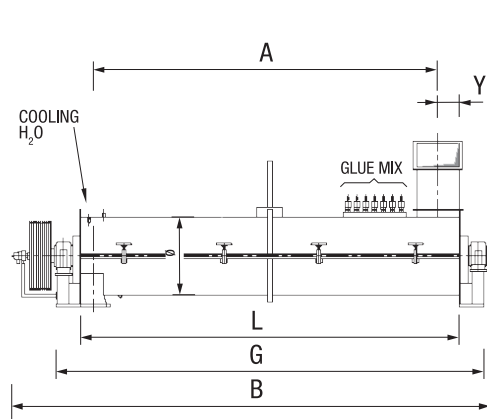

MODEL		OVERALL DIMENSIONS mm										INSTALLED POWER kW/poles		APPROX. WEIGHT kg	
		A	B	C	D	E	F	G	H	Y	L	M1	M2	[5]	[6]
IPL 4 CTS	IPL 4 ASS	2175	3705	1315	1162	1042	1505	3065	870	200	2500	45/4	-	2250	2400
IPL 6 CTS	IPL 6 ASS	2625	4278	1645	1443	1310	1633	3620	1000	225	3000	75/4	0.37/6	2850	3000
IPL 8 CTS	IPL 8 ASS	2625	4278	1645	1443	1340	1633	3620	1000	225	3000	75/4	0.37/6	3200	3400
IPL 10 CTS	IPL 10 ASS	2625	4305	1720	1543	1495	1900	3625	1100	225	3000	75/4	0.37/6	3550	3800
IPL 12 CTS	IPL 12 ASS	3125	4810	1720	1543	1495	1900	4145	1100	225	3000	90/4	0.37/6	3750	4000
IPL 15 CTS	IPL 15 ASS	3625	5305	1870	1593	1575	2086	4620	1200	225	4000	90/4	0.75/6	4400	4700
IPL 22 CTS	IPL 22 ASS	4100	5865	1966	1721	1575	2220	5120	1280	250	4500	110/6	0.75/6	5600	5900
IPL 30 CTS	IPL 30 ASS	4575	6440	2195	1812	1655	2440	5620	1350	275	5000	132/6	1.1/6	6350	6650
IPL 40 CTS	IPL 40 ASS	5575	7440	2260	1812	1700	2550	6620	1350	275	6000	160/6	1.1/6	7500	7800
IPL 50 CTS	IPL 50 ASS	5450	7580	2610	2122	1730	2950	6700	1600	350	6000	200/6	2.2/6	10450	10800
IPL 60 CTS	IPL 60 ASS	5950	8100	2630	2122	1780	3120	7200	1600	350	6500	250/6	2.2/6	-	-

MODEL		MAX. THROUGHPUT kg/h	CHAMBER		COOLING Δt 5°C [1]		COOLING Δt 7°C [2]		[3]
			Ø x L mm	Volume l	l/h	kcal/h	l/h	kcal/h	
IPL 4 CTS	IPL 4 ASS	4000	480 x 2500	452	4230	21150	4230	29610	2.5
IPL 6 CTS	IPL 6 ASS	6000	530 x 3000	662	6770	33860	6770	47400	
IPL 8 CTS	IPL 8 ASS	8000	600 x 3000	847	6950	34750	6950	48650	
IPL 10 CTS	IPL 10 ASS	10000	700 x 3000	1154	8100	40500	8100	56700	
IPL 12 CTS	IPL 12 ASS	12000	700 x 3500	1350	9580	47900	9580	67060	
IPL 15 CTS	IPL 15 ASS	15000	800 x 4000	2010	12260	61300	12260	85820	
IPL 22 CTS	IPL 22 ASS	22000	850 x 4500	2552	16100	80500	16100	112700	
IPL 30 CTS	IPL 30 ASS	30000	900 x 5000	3179	20420	102100	20420	142940	
IPL 40 CTS	IPL 40 ASS	40000	900 x 6000	3815	24500	122500	24500	171500	
IPL 50 CTS	IPL 50 ASS	50000	1200 x 6000	6782	32600	163000	32600	228200	
IPL 60 CTS	IPL 60 ASS	60000	1200 x 6500	7347	35100	175500	35100	245700	

[1] Particle temperature - 45 °C [2] Particle temperature - 65 °C [3] Water pressure drop
 [4] Microcomp CGDW as option [5] CTS blenders [6] ASS blenders