



• MDF • PB • OSB/LSB • PALLET BLOCKS • PRESSED PALLETS • PELLETS • BIOMASS ENERGY



FEEDERS

LONGITUDINAL CHAIN CONVEYOR – LCG

TECHNICAL FEATURES

• Chain conveyor for wood logs feeding • Manufacturing program for different length, width, number of chains, speed, capacity • Heavy construction in order to absorb shocks deriving from logs fall into the conveyor • Chains designed with scraper on the bottom side for rails cleaning.

BENEFITS

• Excellent regularity feeding of raw wood • Great storage volume • Adjustable speed by frequency converter • Fast assembling timing without weldings on site • Rollers chain to decrease energy consumption and wear • Low maintenance cost.

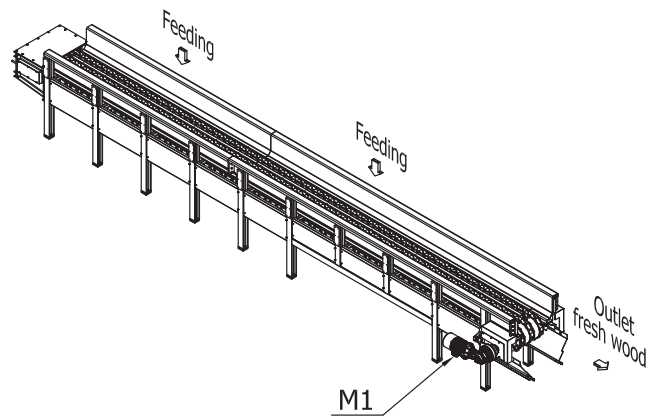
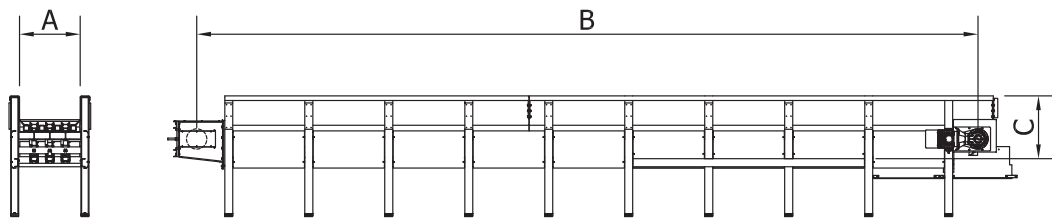

MODEL	OVERALL DIMENSIONS mm ***			
	A	B	C	N° chains
LCG**	800 ÷ 1600	6000 ÷ 24000	1150 ÷ 1650	2 ÷ 6

MODEL	CAPACITY*** m ³ /h	POWER kW	WEIGHT (kg)
		M1	
LCG**	***	5 ÷ 40	***

***According to customer needs

**According to dimensions