

FEEDERS FOR BULKY MATERIALS  
**CHAIN-PLATE FEEDERS**  
**TKK.230 / TKK.350**

FOR URBAN FOREST MATERIAL



#### TECHNICAL FEATURES

- Very strong double-roller chain feeder
- Moving bed equipped with transverse metal plates, overlapped and sealed by profiled shape
- Front shaft fitted with direct transmission
- Rear shaft fitted with chain tensioning devices
- Self cleaning system with: closed bottom – rear reclaim screw conveyors – reclaim belt conveyor
- Automatic lubrication device for chains
- High containment walls.

#### BENEFITS

- Easy loading of urban forest material, such as pallets, crates, cable drums, construction material, demolition furniture, recycled particleboards, etc., bulky or pre-crushed
- Very efficient feeding of pre-crushers (Alligator) or Crushers (Tiger)
- Except for front loader or crane, operators are required from time to time only
- Working speed freely adjustable by using frequency converter
- Automatic cleaning and lubrication
- High performance
- Low maintenance cost.

#### BEST IN CLASS FOR:

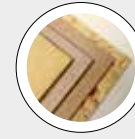

WOOD BASED PANELS:  
PB/SPB

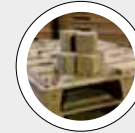

PRESSED WOOD PACKAGING:  
PALLET BLOCKS



PELLETS & ENERGY:  
WOOD PELLETS AND  
BLACK PELLETS  
LIME

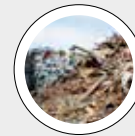

WOOD RECYCLING AND  
WASTE TREATMENT:  
WASTE

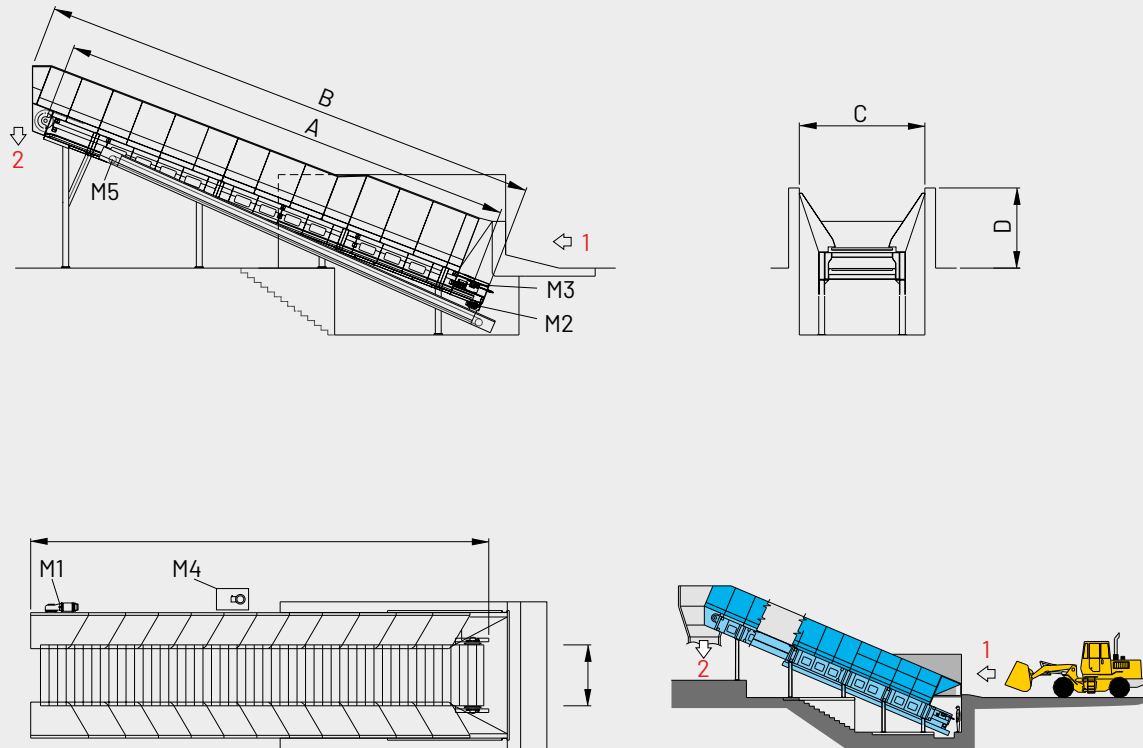

1 = FEEDING  
2 = DISCHARGE

M1 = DOUBLE CHAIN  
PLATE-FEEDER

M2 = CLEANING SCREW  
M3 = CLEANING SCREW

M4 = LUBRICATION DEVIDE  
M5 = CLEANING BELT

MODEL	OVERALL DIMENSIONS mm					
	A	B	C	D	E	F
TKK.230/1200	12000	14167	4700	3000	14832	2300
TKK.230/1700	17000	18914	4700	3000	17140	2300
TKK.230/2100	21000	23980	4700	3000	20500	2300
TKK.350/1200	12000	13760	5800	3000	13215	3500
TKK.350/1700	17000	18760	5800	3000	17815	3500
TKK.350/2100	21000	23980	5800	3000	20500	3500

MODEL	CAPACITY* BULK m <sup>3</sup> /h	INSTALLED POWER kW					WEIGHT APPROX. kg
		M1*	M2	M3	M4	M5**	
TKK.230/1200	200-230	5,5	0,55	0,55	0,12	2,2	22000
TKK.230/1700	200-230	5,5	0,55	0,55	0,12	2,2	27000
TKK.230/2100	200-230	7,5	0,55	0,55	0,12	2,2	27000
TKK.350/1200	300	5,5-15	0,55	0,55	0,25	2,2	35000
TKK.350/1700	300-350	5,5-15	0,55	0,55	0,25	3,0	44000
TKK.230/2100	300-350	11-15	0,55	0,55	0,25	3,0	50000

\*According to feeding material

\*\*Reclaim belt for self cleaning system as option