

DOUBLE-ROTOR PRE-CRUSHERS

ALLIGATOR-D

FROM URBAN FOREST TO READY CHIPS

**TECHNICAL FEATURES**

• Integrated system including conveying belt and deferrizator • Very large feeding hopper for bulky material • Low-speed crushing rotors equipped with strong teeth • Hydraulic drive protected from overloads • Discharge sizing screen for pre-crushed material.

BENEFITS

• High capacity • Drastic volume reduction of bulky recycling, i.e. from 60-80 to 130-150 kg/m³ bd • Easier & cheaper transportation of pre-crushed material • Full protection from overloads, e.g. from foreign bodies • Compact, simple, versatile, highly reliable and efficient system • Minimum noise • Very low maintenance.

BEST IN CLASS FOR:

WOOD BASED PANELS:
PB/SPB



PRESSED WOOD PACKAGING:
PALLET BLOCKS



PELLETS & ENERGY:
WOOD PELLETS AND
BLACK PELLETS
LIME



WOOD RECYCLING AND
WASTE TREATMENT:
WASTE

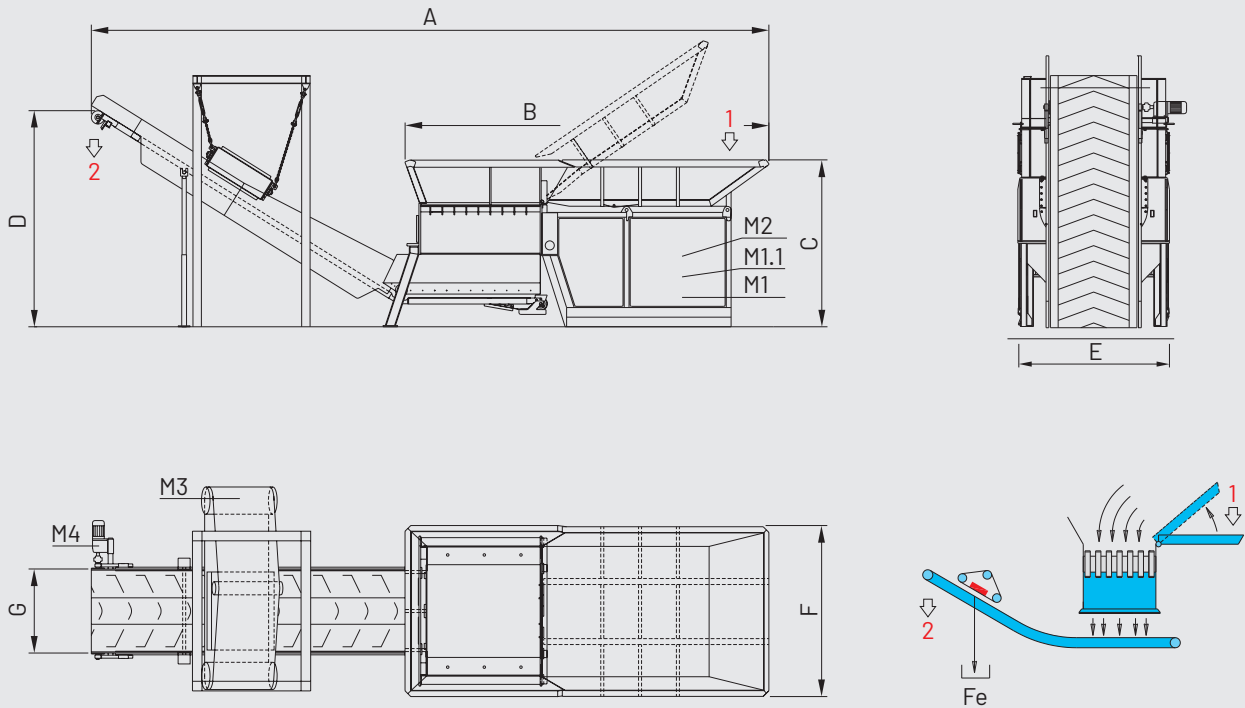

1 = INFEED
2 = OUTFEED

Fe = FERROUS POLLUTANTS
M1 = MAIN MOTOR
M1.1 = MAIN MOTOR

M2 = HEAT EXCHANGER FOR OIL
M3 = OVERBELT MAGNET GEAR MOTOR
M4 = BELT CONVEYOR GEAR MOTOR

| MODEL | OVERALL DIMENSIONS mm | | | | | | |
|-------------------------|-----------------------|------|------|------|------|------|------|
| | A | B | C | D | E | F | G |
| ALLIGATOR 85D-600/285 | 14680 | 6060 | 4209 | 4060 | 5520 | 2260 | 1400 |
| ALLIGATOR 85D-220/200-W | 15257 | 2200 | 4410 | 4500 | 5520 | 2450 | 1400 |

| MODEL | CAPACITY* t/h | INSTALLED POWER kW | | | | | | WEIGHT APPROX. kg |
|-------------------------|------------------|--------------------|------|---------|-----|----|-------|----------------------|
| | | M1 | M1.1 | M2 | M3 | M4 | R** | |
| ALLIGATOR 85D-600/285 | 40-90 | 160 | 160 | 4 x 5,5 | 2,2 | 22 | 3 x 2 | 26000 |
| ALLIGATOR 85D-220/200-W | 19-30 | 160 | 160 | 4 x 5,5 | - | 22 | - | 26000 |

*According to type-volume of material and infeed efficiency

**Resistors for heating oil - option