

VIBRATING FEEDER – AVG / AVE



TECHNICAL FEATURES

- Ideal to install it after a chipper or to feed rechipper or flakers
- Easy transport of chips or flakes to enlarge the wood material
- Optimal speed and distribution of the chips
- Possibility to setup different angle according to chips-moisture and size
- High reliability and low maintenance
- Suspension springs with regulation
- Possible installation of a magnetic drum at the outlet.

BEST IN CLASS FOR:

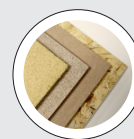

WOOD BASED PANELS:
MDF/HDF
PB/SPB



PRESSED WOOD PACKAGING:
PALLET BLOCKS
PRESSED PALLETS



PELLETS & ENERGY:
WOOD PELLETS AND
BLACK PELLETS
GREEN FUELS AND BIOMASS
LIME



WOOD RECYCLING AND
WASTE TREATMENT:
WASTE

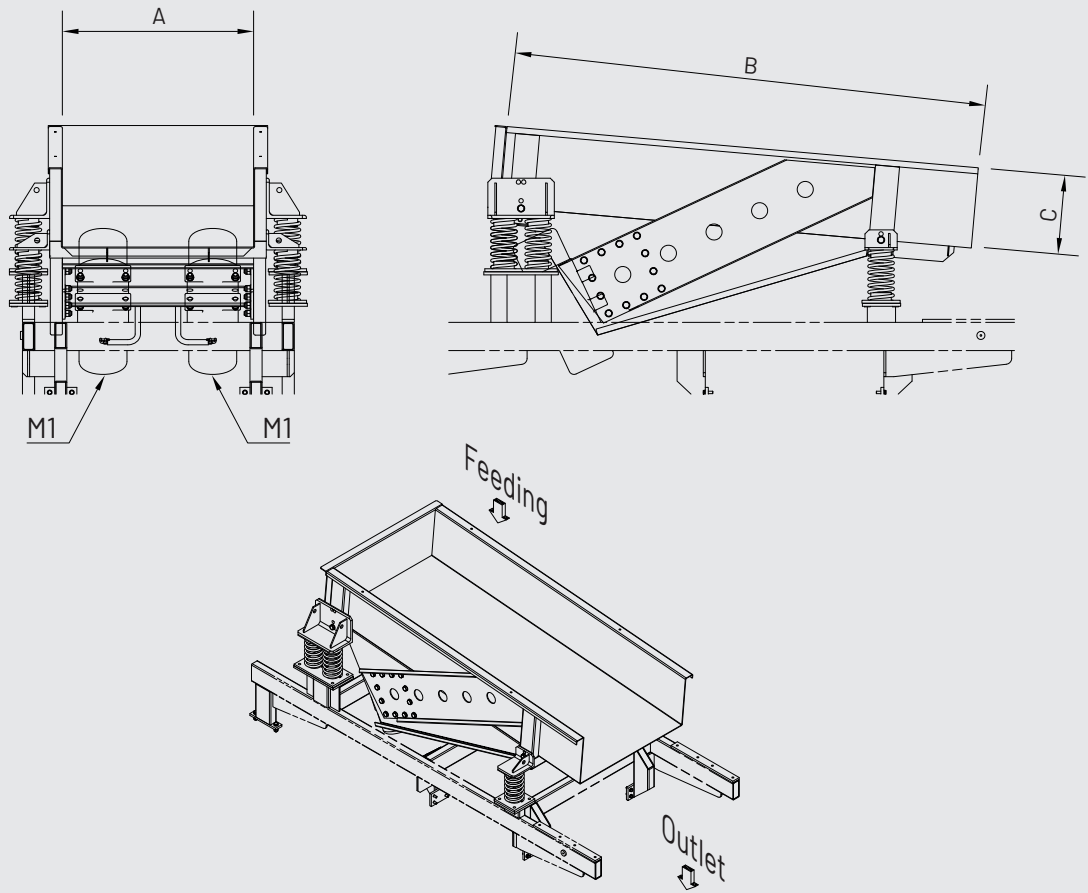

M1 = VIBRATING MOTOR

MODEL	OVERALL DIMENSIONS mm ^{***}		
	A	B	C
AVG** / AVE**	500 ÷ 2000	1500 ÷ 7000	200 ÷ 600

MODEL	CAPACITY m ³ /h	POWER kW	WEIGHT kg
		M1	
AVG** / AVE**	***	1 ÷ 22	100 ÷ 3600

***According to customer needs

**According to dimensions