

METERING BIN

BBPL

HIGHLY ACCURATE MATERIAL METERING AND WEIGHING

**BEST IN CLASS FOR:**

WOOD BASED PANELS:

PB/SPB

OSB/LSB/FOSB

This bin has been designed to solve metering problems for facilities with small or average capacities. Its storage system and ample volume are two features which contribute to keeping the volumetric weight of the material to be extracted constant, irrespective of the bin's filling level, resulting in a perfectly even extraction. The material is distributed and leveled inside the bin by means of a set of screws or rakeback conveyor system, while a set of doffing roll disks at the outlet ensures that the material is evenly distributed over the whole weighing belt. The method adopted for particle metering is that of conveyor belt speed variation. A weighing belt is located at the end of the conveyor belt, which, thanks to a special mechanical-electronic system, is able to determine the instantaneous throughput of the material.

MAIN FEATURES

- Very sturdy construction
- Screw or rakeback conveyor leveling system
- Particles discharged by rotating doffing roll shafts to optimise and fluidise particle flow
- Brush for cleaning conveyor belt
- Belt sliding surface made from galvanized iron sections
- Level of the material in the bunker controlled by a set of capacitive levels
- Option - level controlled by prior weighing of the whole bunker.

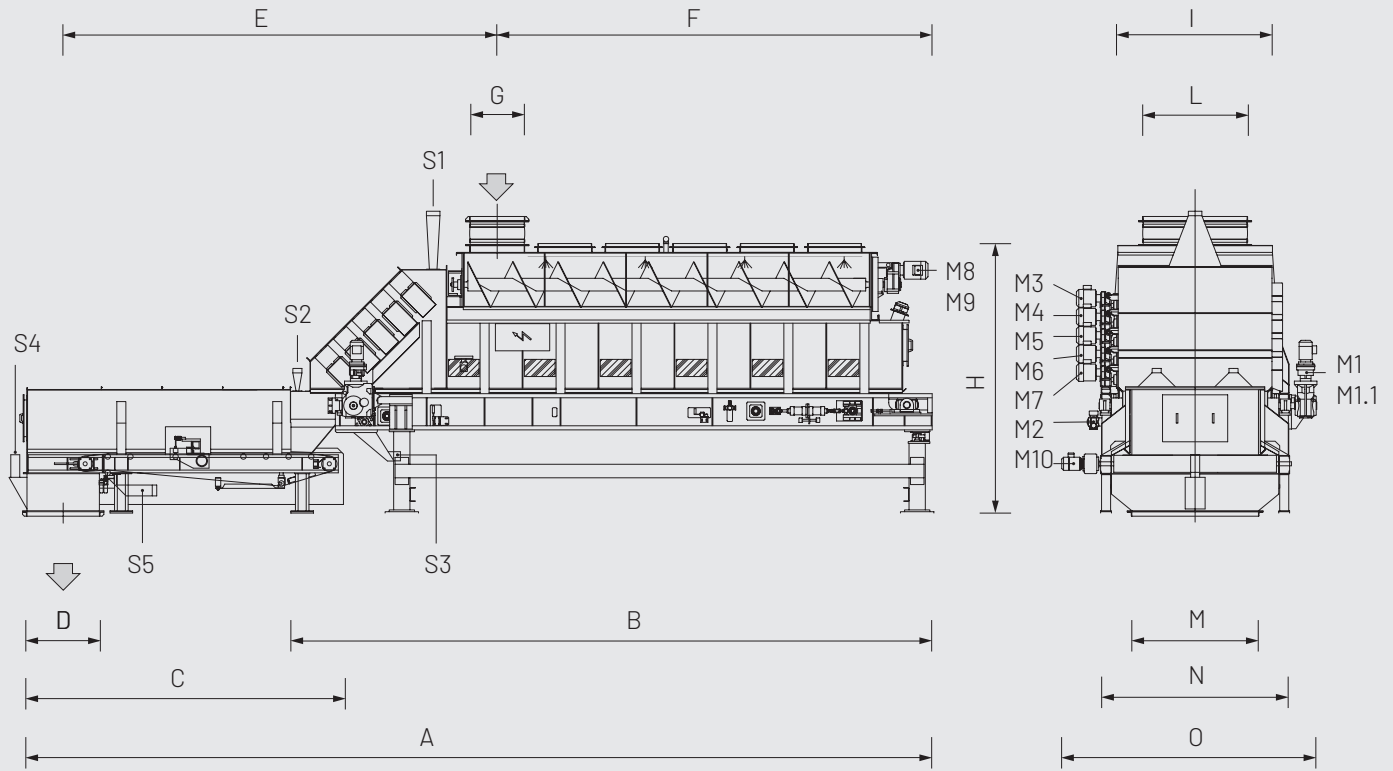

MODEL	OVERALL DIMENSIONS mm												
	A	B	C	D	E	F	G	H	I	L	M	N	O
BBPL 15/2580	10500	7100	4500	300+800	4800	4800	600	3300	1410	750	1000	1670	2300
BBPL 25/2580	10500	7090	4500	300+800	4800	4800	600	3300	1710	1150	1400+1640	2070	2700
BBPL 60-20.25/2580	12500	9400	4500	300+800	5700	6200	600	4100	2110	1550	1400+1700	2500	3200
BBPL 60-20.40/2580	12500	9400	4500	300+800	5700	6200	600	4100	2110	1550	1640+1700	2500	3200

MODEL	MAX THROUGHPUT		MAX BIN VOLUME m ³	TOTAL SUCTION S1-S2-S3-S4-S5 m ³ /h	WEIGHT kg
	kg/h	m ³ /h			
BBPL 15/2580	According to bulk density	240	6	6130	9500
BBPL 25/2580		360	8	7560	11500
BBPL 60-20.25/2580		600	20	9640	13500
BBPL 60-20.40/2580		600	20	11240	15000

MODEL	INSTALLED POWER kW								
	M1	M1.1	M2	M3-M7	M8-M11	M12	M12.1	M13	M13.1
BBPL 15/2580	0.37±1.1	0.078	0.37	1.1x5	2.2x2	0.75	0.078	1.5±2.2	0.087
BBPL 25/2580	0.37±1.5	0.078	0.37	1.1x5	2.2x2	0.75	0.078	2.2±3.0	0.091
BBPL 60-20.25/2580	1.5	-	0.37	1.5x5	3.0x4	0.55±1.1	0.087	2.2±3.0	0.091
BBPL 60-20.40/2580	1.5	-	0.37	1.5x5	3.0x4	0.75±1.5	0.087	2.2±3.0	0.091