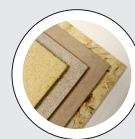

## RAW BOARD SCALE

**BPP**

CONTINUOUS RAW BOARD SCALE

**BEST IN CLASS FOR:**

## WOOD BASED PANELS:

PB/SPB

OSB/LSB/FOSB

MDF/HDF

This weighing system is composed of load cells, of a suitable load, to support the conveyor unit. An IMAL electronic digital amplifier supplies the voltage, appropriately filtered and adjusted, to the cells, and amplifies the proportional weight signal. This value can then be transmitted to other quality control systems, like the thickness gauge, so that density may be calculated.

The integrated display and keyboard are used to programme the software processing parameters, especially with regard to the tare and full scale values.

**MAIN FEATURES**

- Digital signal processing • Highly accurate • Non-stop board weighing
- Possibility of linking up with other systems • Simple to install.

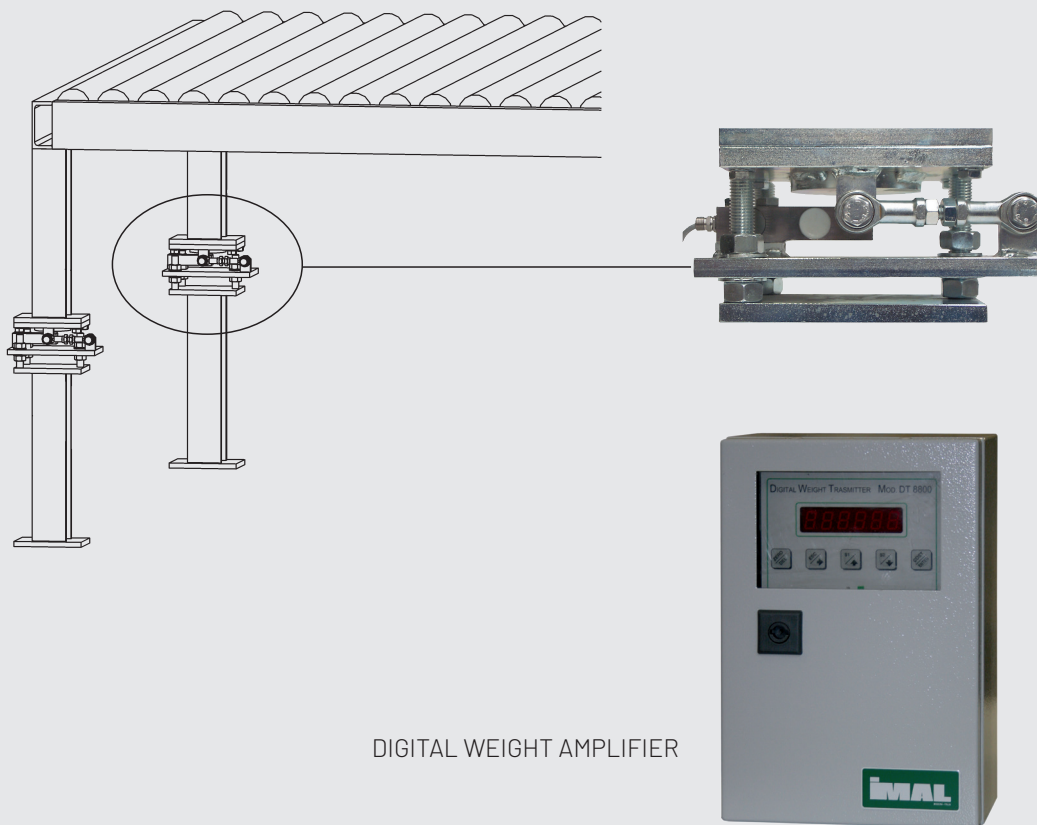

DIGITAL WEIGHT AMPLIFIER

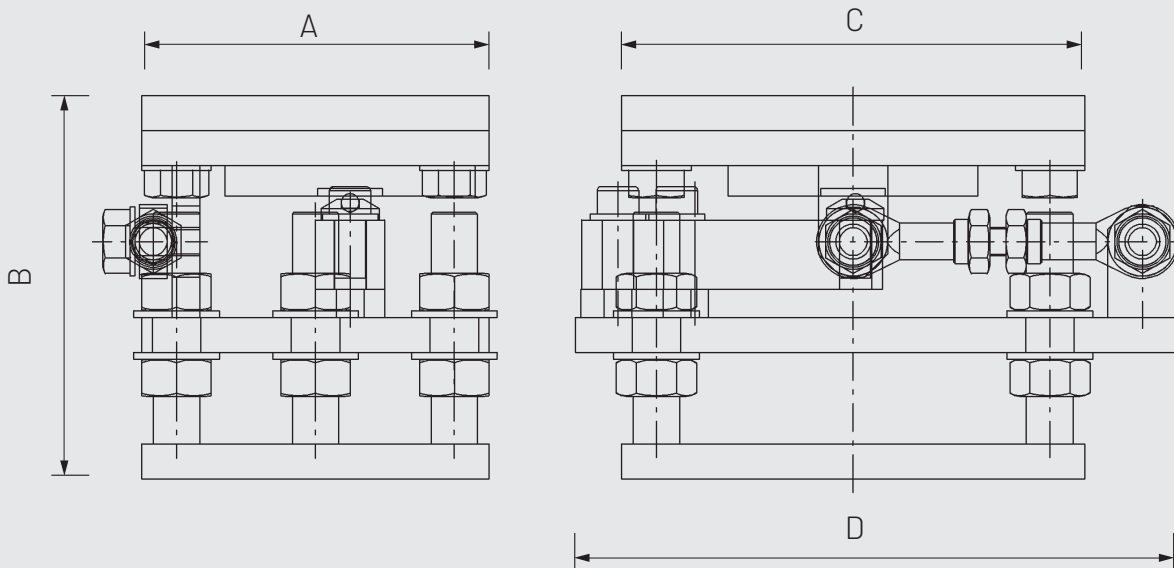

MODEL	OVERALL DIMENSIONS mm			
	A	B	C	D
BPP	150	165	200	260