

CHAIN CONVEYORS – TCG

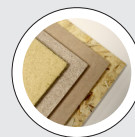

BEST IN CLASS FOR:



WOOD BASED PANELS:

MDF/HDF

PB/SPB

OSB/LSB/FOSB



PRESSED WOOD PACKAGING:

PALLET BLOCKS

PRESSED PALLETS



PELLETS & ENERGY:

WOOD PELLETS AND
BLACK PELLETS

GREEN FUELS AND BIOMASS

TECHNICAL FEATURES

- Chain conveyor for wood logs or slabs feeding
- Manufacturing program for different length, width, number of chains, speed, capacity
- Modular design in order to extend sizes of the conveyor once needed
- Independent tensioning system for each individual chains.

BENEFITS

- Excellent regularity feeding of any type of raw wood
- Great storage volume
- Adjustable speed by frequency converter
- Fast assembling timing without weldings on site
- Rollers chain to decrease energy consumption and wear
- Low maintenance cost.

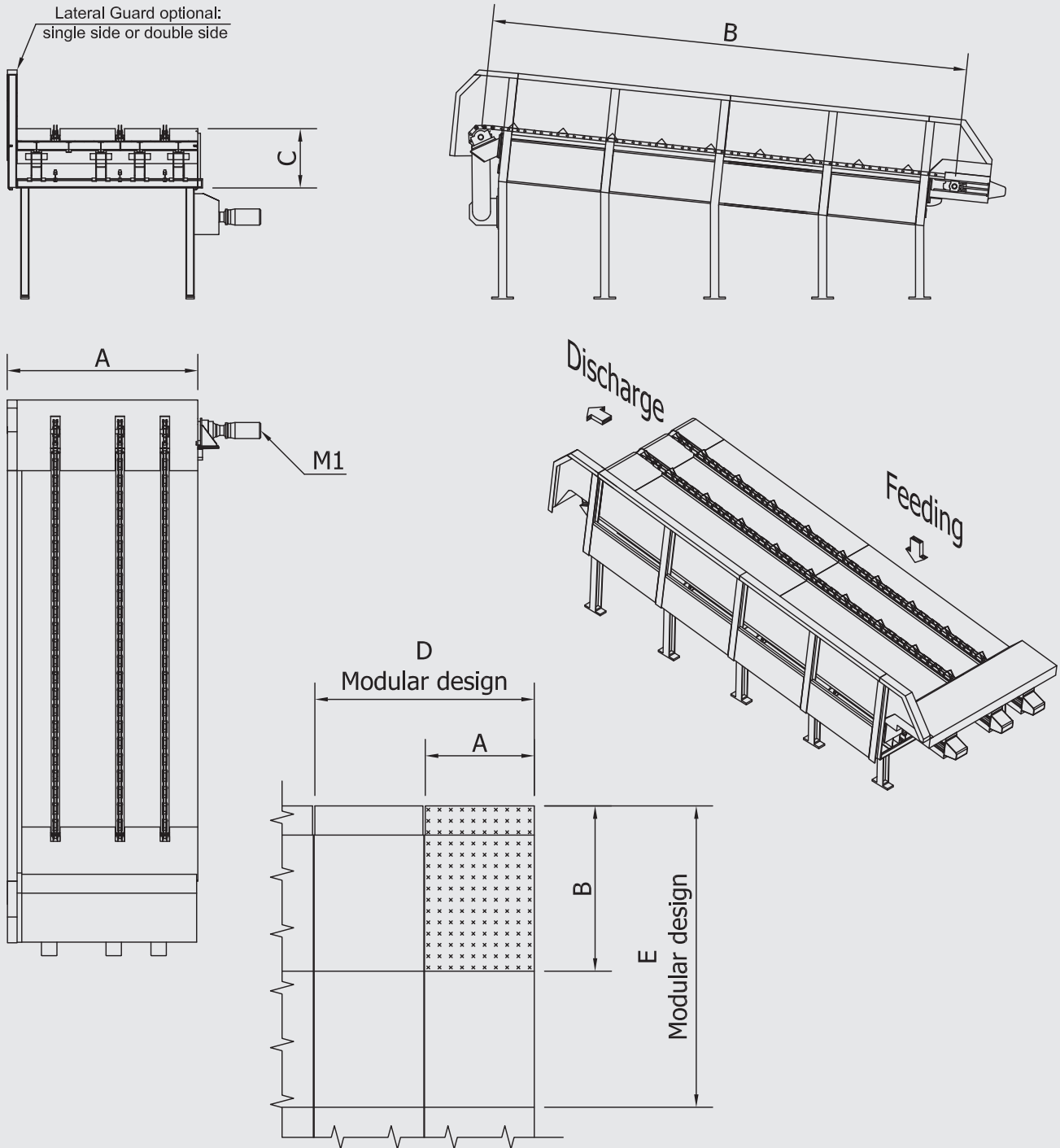

M1 = VIBRATING MOTOR

MODEL	OVERALL DIMENSIONS mm ***					
	A	B	C	D	E	N° chains
TCG**	1000 ÷ 2000	2500 ÷ 4000	1200	A x n°Module	B x n°Module	2 ÷ 12

MODEL	CAPACITY*** m³/h	POWER kW	WEIGHT (kg)
		M1	
TCG**	***	3 ÷ 30	***

***According to customer needs

**According to dimensions