

DEBARKERS
CAM CLEANERS – CSC



TECHNICAL FEATURES

- Screening bed of steel star shaft, with cams design section for barks and other pollutant exhaust
- Bearing maintenance-free and transmission system
- Working speed according to chipping train
- Reversible flow direction when needed.

BENEFITS

- Excellent removal of barks and other pollutant material, also snow in winter time
- Low maintenance cost
- Adjustable working speed.

BEST IN CLASS FOR:

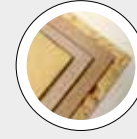

WOOD BASED PANELS:
 PB/SPB
 OSB/LSB/FOSB
 MDF/HDF

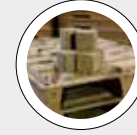

PRESSED WOOD PACKAGING:
 PALLET BLOCKS
 PRESSED PALLETS



PELLETS & ENERGY:
 GREEN FUELS AND BIOMASS
 WOOD PELLETS AND
 BLACK PELLETS

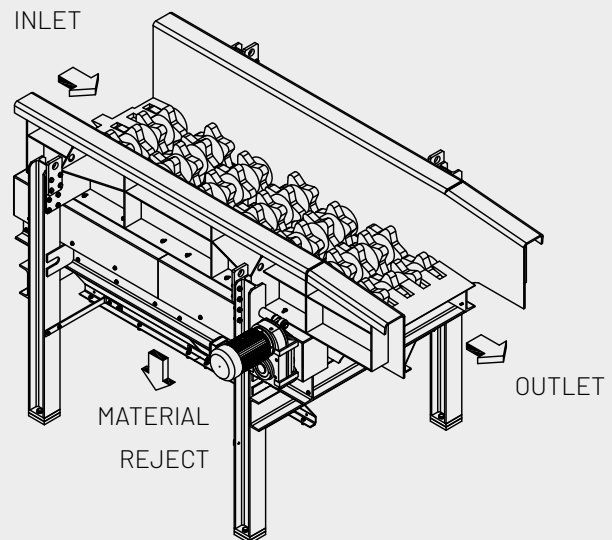
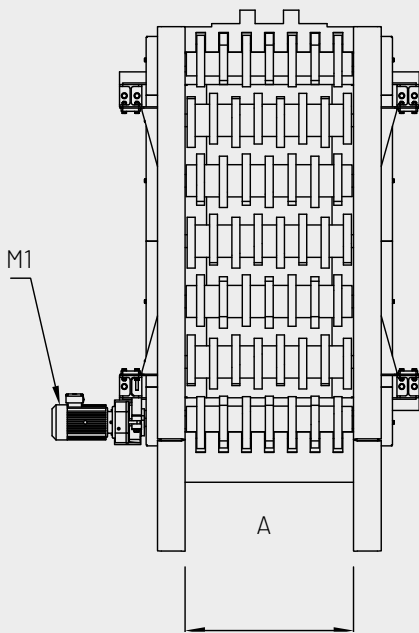
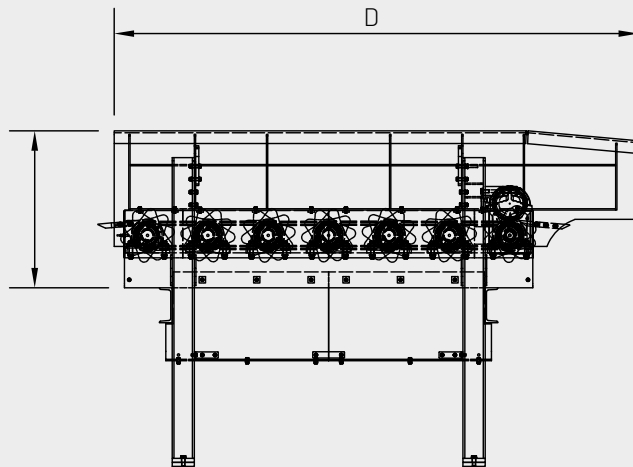
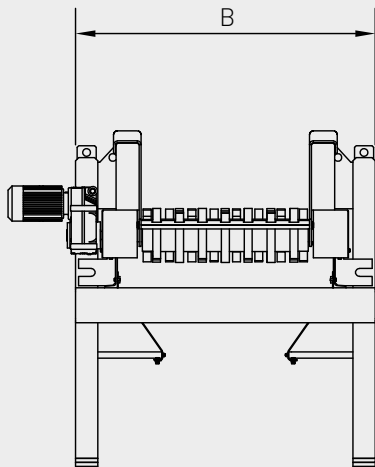

M1 = VIBRATING MOTOR

| MODEL | OVERALL DIMENSIONS mm *** | | | | |
|--------|---------------------------|----|------------|-------------|------------|
| | A | B | C | D | N° rollers |
| CSC ** | ** | ** | 900 ÷ 1400 | 2600 ÷ 6000 | ** |

| MODEL | CAPACITY m³/h | POWER kW | WEIGHT kg |
|--------|---------------|----------|-----------|
| | | M1 | |
| CSC ** | ** | 3 ÷ 18,5 | ** |

*** According to customer needs

** According to dimensions