

DCC – DRY CLEANER FOR CHIPS

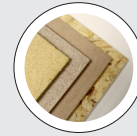

BEST IN CLASS FOR:



WOOD BASED PANELS:
MDF/HDF
PB/SPB
INSULATION BOARDS



PRESSED WOOD PACKAGING:
PALLET BLOCKS



PELLETS & ENERGY:
WOOD PELLETS AND
BLACK PELLETS

TECHNICAL FEATURES

- High-tech chip cleaning system suitable to remove every kind of heavy pollutants from the chips, i.e. sand, stones, minerals, etc.
- Special design for recycling-high polluted chips
- Cleaning chamber provided of perforated screens and front step to stop heavy pollutants
- Very strong oscillators for cleaning chamber
- High pressure pneumatic circuit provided of adjustable speed pulsator
- Special re-classifiers to separate the heavy pollutants from chip flow
- Suction hopper and cyclone in order to prevent pollution.

BENEFITS

- Removal of any type of heavy pollutants, i.e. sand, stones, minerals, etc.
- Unbeatable cleaning efficiency
- Dramatic reduction (up to 40-70%) of raw material cost using recycled chips
- Cost reduction till 50% for knives and wearing parts of knife ring flakers
- High reliability
- Very low maintenance cost
- Low energy consumption, i.e. 0,5-0,6 kW/m³/h of bulk chips
- Installation free from pollution.

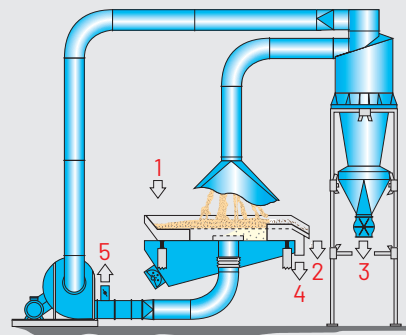
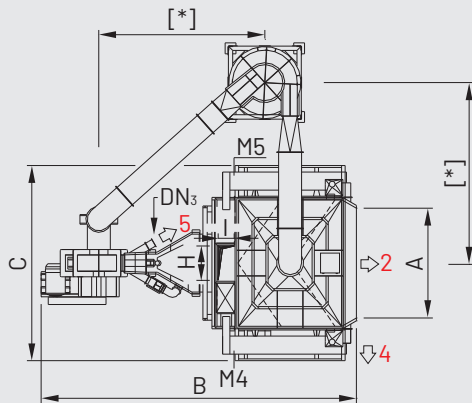
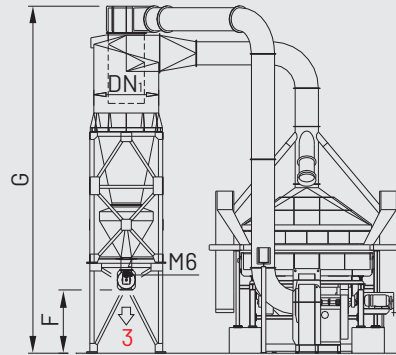
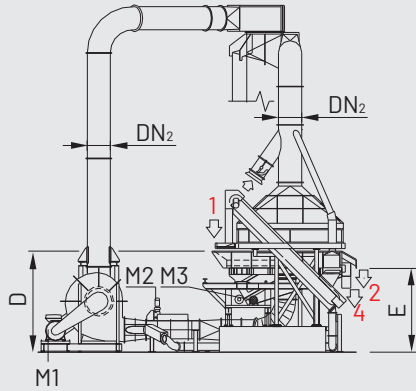

FOR DRY MATERIAL ONLY:
 1= POLLUTED CHIPS
 2= CLEAN CHIPS
 3= VOLATILE WOOD PARTICLES
 4= HEAVY POLLUTANTS
 5= EXHAUST AIR

M1= FAN DRIVE
 M2= PULSATOR
 M3= EXCITER

M4= RECYCLE BELT
 M5= RECYCLE BELT
 M6= ROTARY VALVE OUT



2

4

MODEL	OVERALL DIMENSIONS mm											
	A	B	C	D	E	F*	G*	H	I	DN ₁	DN ₂	DN ₃
DCC 50 MC	942	5965	3390	1932	1518	2287	7211	500	500	1120	450	150
DCC 70 MC	1524	7481	3550	2480	1981	1762	7909	700	500	1400	450	150
DCC 100 MC	2304	7590	4550	2697	2230	1750	8748	900	500	1600	500	1150
DCC 150 MC	3038	8725	5400	2800	2361	1750	9605	1000	500	1800	640	200
DCC 250 MC	3738	10588	6140	3300	2887	2186	11680	1200	500	2000	750	200

*Dimensions according to needed layout

MODEL	CAPACITY BULK CHIPS m ³ /h	INSTALLED POWER kW								EXHAUST AIR m ³ /h	WEIGHT APPROX. kg
		M1	M2	M3	M4	M5	M6	TOTAL			
DCC 50 MC	40	37	0,75	4,0	0,75	-	1,5	44,00	2000	8090	
DCC 70 MC	60	45	0,75	7,5	0,75	0,75	1,5	56,25	2200	11500	
DCC 100 MC	90	55	0,75	15,0	0,75	0,75	1,5	73,75	2500	13710	
DCC 150 MC	130	75	0,75	15,0	0,75	0,75	1,5	93,75	4500	17000	
DCC 250 MC	180	132	1,10	22,0	0,75	0,75	1,5	158,10	4500	21000	