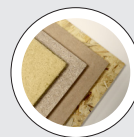

CLEANING SYSTEM FOR PRE PRESS VENTING BELT

**DYNACLEANER****BEST IN CLASS FOR:**

WOOD BASED PANELS:

PB/SPB

OSB/LSB/FOSB

MDF/HDF

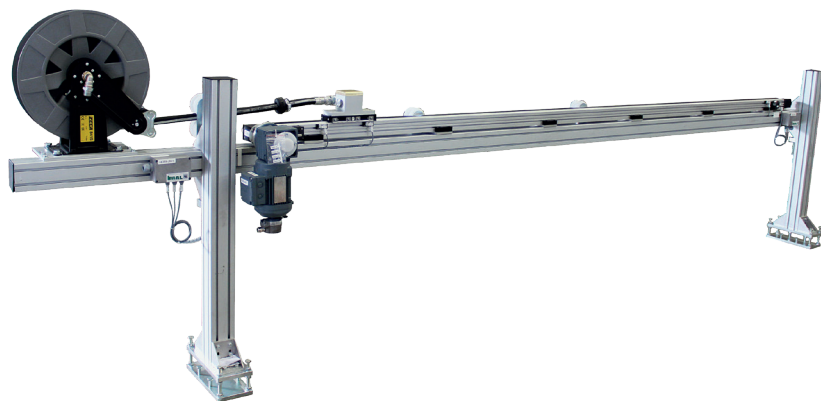

Motorized DynaCleaner system for cleaning venting belt with a Hi-impact single nozzle jet of compressed air.

The system, which may be programmed for a continuous or step by step cleaning cycle, cleans the belt thoroughly without the need to stop the production line.

The system consists of a motorized rail for the sprayer nozzle to run on, the position of which is monitored by encoder so that cleaning may be programmed. The brass cleaning head is in contact with the belt as it slides along to ensure that the jet of air travels smoothly and that cleaning operations are performed efficiently.

The compact system is easily installed on all types of pre-presses or systems equipped with venting belts.

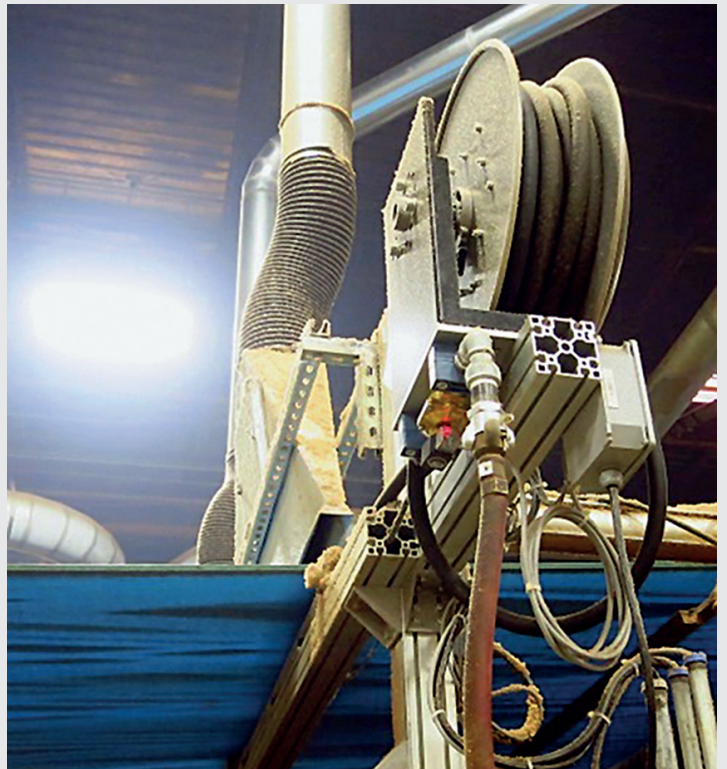
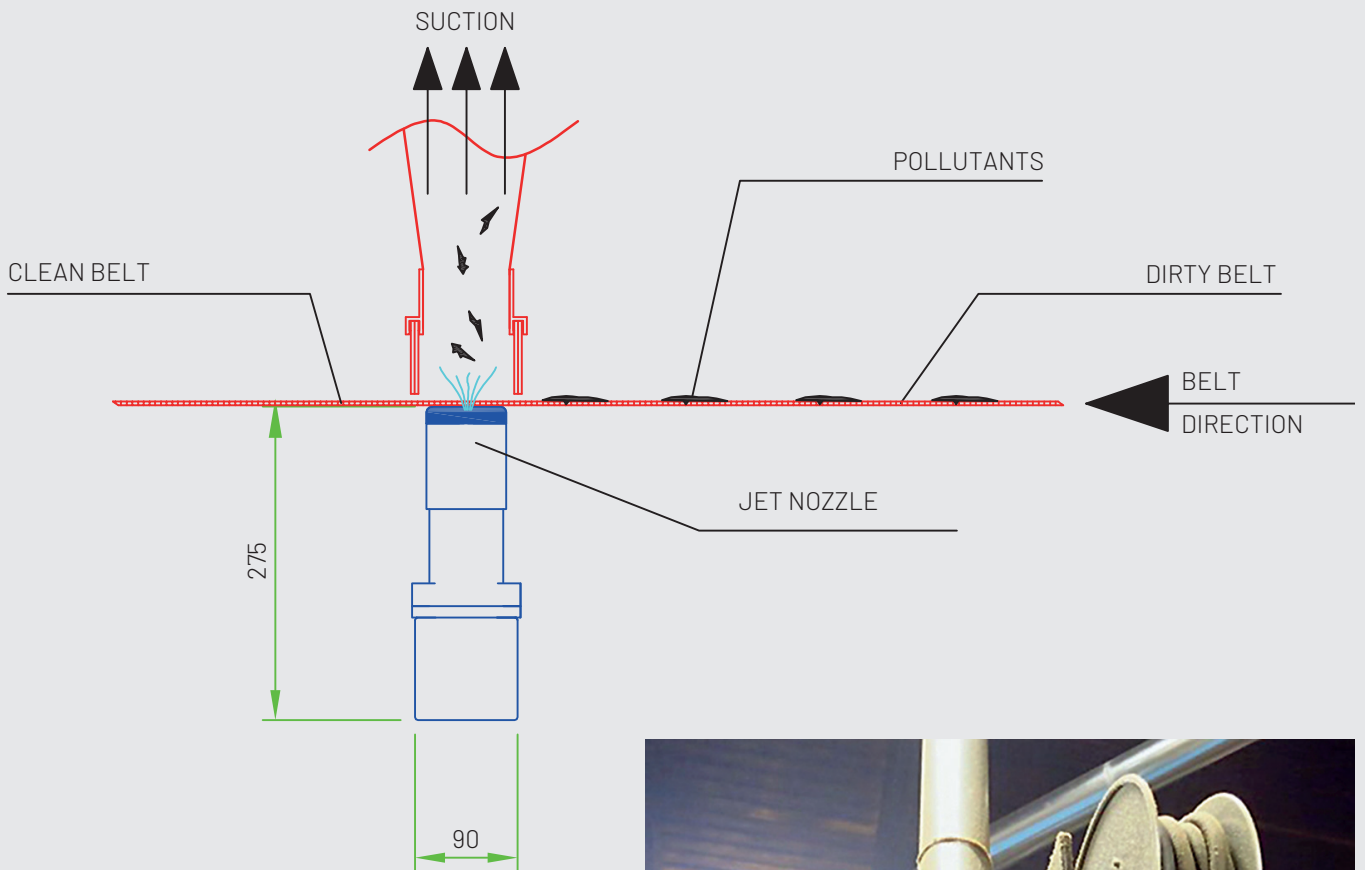

TECHNICAL DATA	
DIMENSIONS	in relation to the line
INSTALLED POWER	0.12 kW + encoder
BELT SPEED	0.1 - 2500 mm/sec
CLEANING CYCLE	Programmable: time mode, continuous mode, step mode, zone mode