

NON FERROUS METALS REMOVERS

EDDY CURRENT SEPARATORS**TECHNICAL FEATURES**

• Feeding & spreading unit (Option) • Large belt conveyor fitted with ultra-strong induction drum • Magnetic plates & dust drawer to keep the belt clean • Drive systems for belt and induction drum • Assembled unit • Electrical cabinet including frequency converters and PLC.

BENEFITS

• Removal of coarse non-ferrous metals from chips • Great production capacity • Unbeatable efficiency and reliability • Low maintenance.

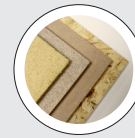
BEST IN CLASS FOR:

WOOD BASED PANELS:
MDF/HDF
PB/SPB
INSULATION BOARDS



PRESSED WOOD PACKAGING:
PALLET BLOCKS



PELLETS & ENERGY:
WOOD PELLETS AND
BLACK PELLETS
LIME



WOOD RECYCLING AND
WASTE TREATMENT:
WASTE

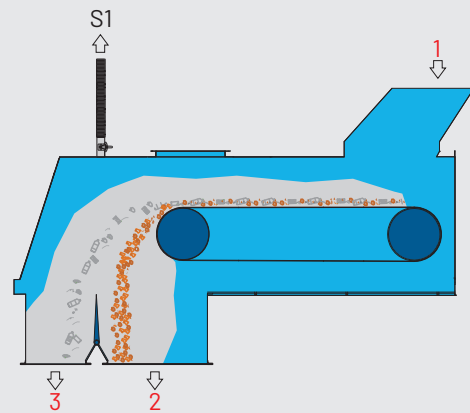
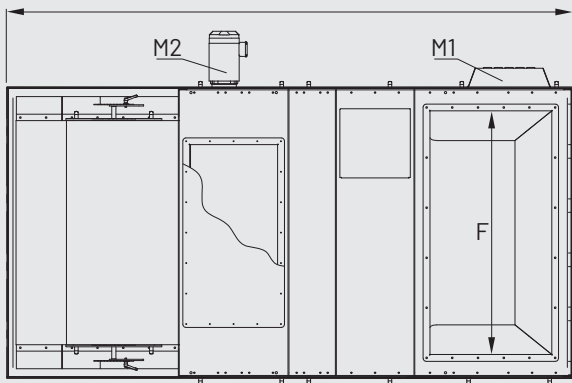
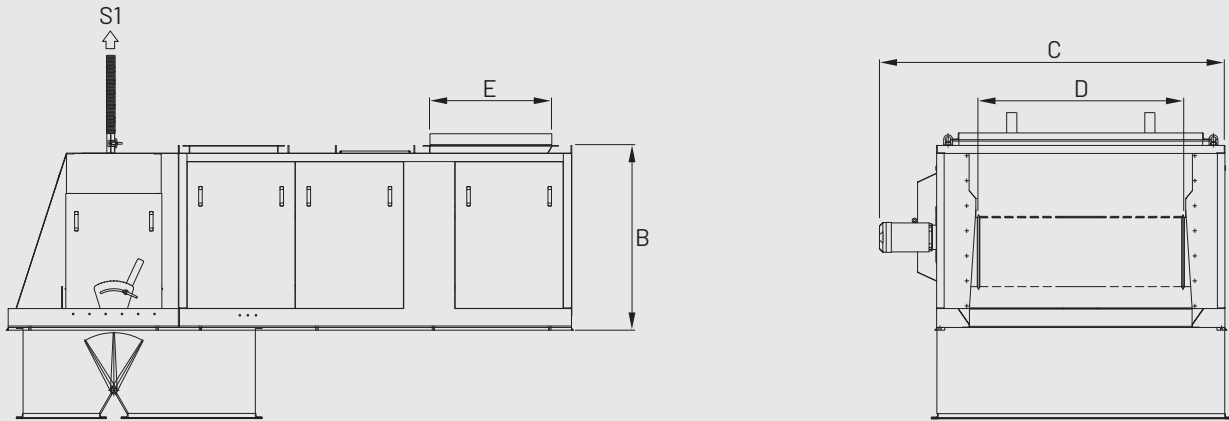

1 = POLLUTED MATERIAL
2 = CLEANED MATERIAL

3 = NON FERROUS METAL REMOVED
M1-M2 = MAIN MOTOR

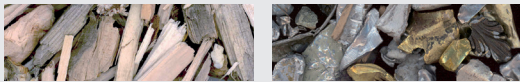

2

3

MODEL	OVERALL DIMENSIONS mm					
	A	B	C	D	E	F
ECS 100/220	4160	1340	2000	1000	900	1300
ECS 150/220	4160	1340	2550	1500	900	1800
ECS 200/220	4160	1340	3050	2000	900	2300
ECS 250/300	5180	1340	3510	2500	900	2800

*If required extraction can be performed from the opposite side

MODEL	CAPACITY m ³ /h	INSTALLED POWER kW		ELECTRIC CUBICLE				SUCTION S1		WEIGHT APPROX. kg
		M1	M2					SUCTION m ³ /h	SUCTION PRESSURE Pa	
ECS 100/220	80	2,2	4	HEIGHT 2100 mm	WIDTH 800 mm	DEPTH 400 mm	WEIGHT 150 kg	2x800	2x100	2200
ECS 150/220	130	3	5,5					2x800	2x100	2500
ECS 200/220	180	3	5,5					2x800	2x100	3300
ECS 250/300	220	3	7,5					2x800	2x100	6500