

FERROUS METALS REMOVERS

ELECTROMAGNETIC DRUMS – MD.EL

FOR BULKY OR PRE-CRUSHED RECYCLED WOOD

**TECHNICAL FEATURES**

- Front shaft fitted with direct transmission • System for special applications
- Big and extra-strong electromagnetic drum fitted with bearings and supports
- Drive system.

BENEFITS

- Very high efficiency and reliability • Strong removal of ferrous pollutants (also huge pcs) from bulky or pre-crushed recycling wood, e.g. before pre-crusher, crusher or drum chipper • Simple installation • Low maintenance.

BEST IN CLASS FOR:

WOOD BASED PANELS:
MDF/HDF
PB/SPB
INSULATION BOARDS



PRESSED WOOD PACKAGING:
PALLET BLOCKS



PELLETS & ENERGY:
WOOD PELLETS AND
BLACK PELLETS
LIME



WOOD RECYCLING AND
WASTE TREATMENT:
WASTE

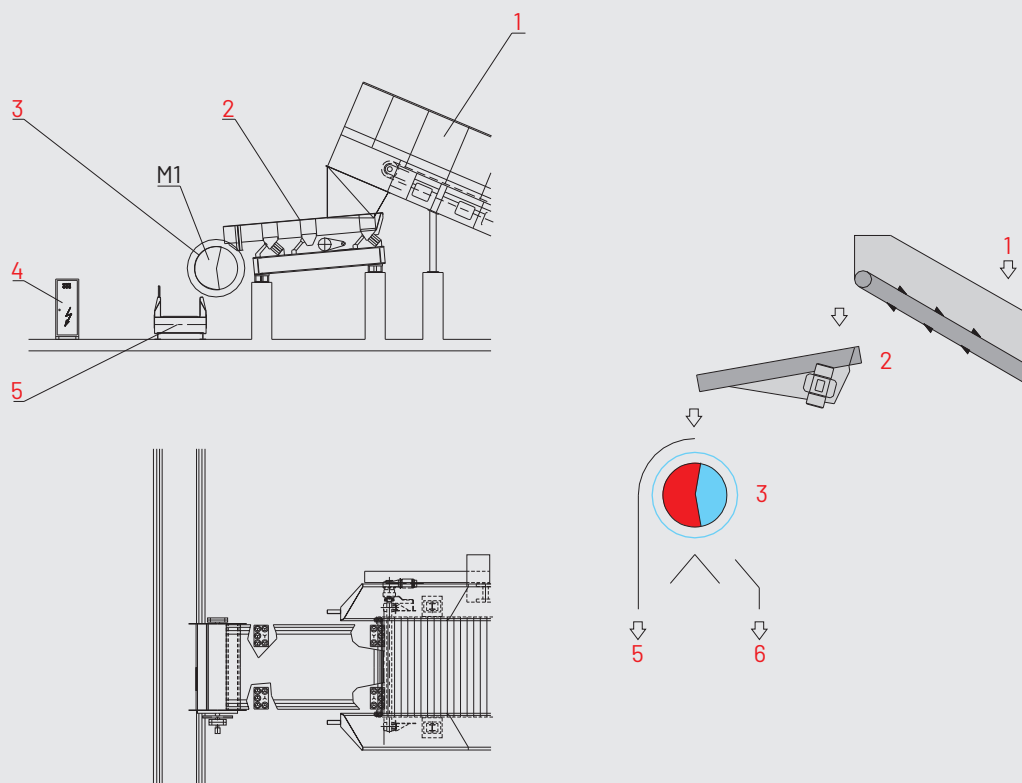

1 = FEEDING

2 = VIBRATING CHANNEL

3 = ELECTROMAGNETIC DRUM

4 = ELECTRIC CUBICLE

5 = CLEAN CHIPS TO U-FEEDER OF CRUSHER

6 = FERROUS METAL REMOVED

M1 = MAGNETIC DRUM ROTATION



5



6

MODEL	CAPACITY BULKY STUFF m ³ /h	ELECTROMAGNETIC DRUM mm		INSTALLED POWER kW		ELECTRIC CUBICLE kW	WEIGHT APPROX. kg
		DIAM.	WIDTH	M1			
MD.1500x2500.MRD-EL	440	1500	2500	9,2		20	17000
MD.1500x3000.MRD-EL	530	1500	3000	9,2		20	19800