

EOLO**BEST IN CLASS FOR:**

WOOD BASED PANELS:
PB/SPB



PRESSED WOOD PACKAGING:
PALLET BLOCKS



PELLETS & ENERGY:
WOOD PELLETS AND
BLACK PELLETS
LIME

**TECHNICAL FEATURES**

- Interconnecting ducts with flaps to adjust the fluidizing speed
- Uniform air distribution on the whole belt width
- Fan and belt motor regulated by frequency converter.

BENEFITS

- Heavy material removal (stones, glass, heavy plastic, etc...) from chips flow by air blowing
- Simple construction
- Easily adjustable separation into two fractions
- High separation efficiency
- Great reliability
- Very low maintenance costs
- Very low energy consumption.

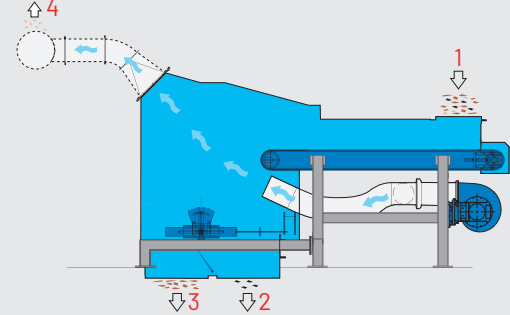
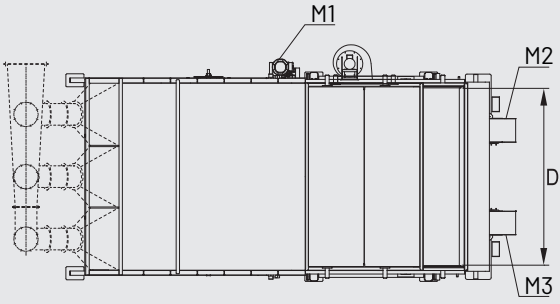
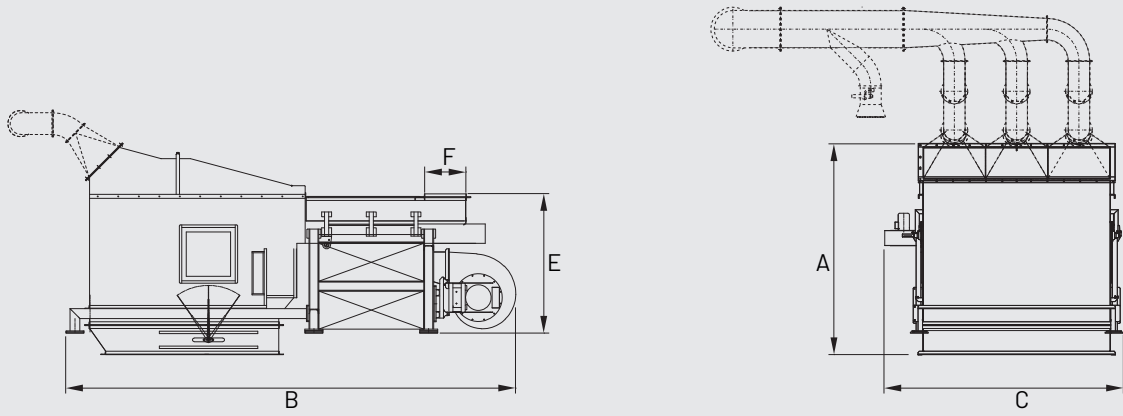

1 = FEEDING 3 = CLEAN CHIPS M1 = BELT MOTOR M3 = MOTOR FAN
 2 = HEAVY POLLUTANTS 4 = LIGHT POLLUTANTS M2 = MOTOR FAN M4 = MOTOR FAN FOR BELT

MODEL	OVERALL DIMENSIONS APPROX. mm						TOTAL INSTALLED POWER kW	CAPACITY BULK CHIPS m ³ /h	NET WEIGHT APPROX. kg	EXHAUST AIR m ³ /h
	A	B	C	D	E	F				
EOLO 10	2580	5500	1680	1000	1690	500	13,5	70	2800	10000
EOLO 15	2580	5700	2180	1500	1690	500	21,5	100	3300	15000
EOLO 22	2723	5700	2880	2200	1690	500	25	150	4650	20000
EOLO 30	2760	6870	3755	3000	1910	500	41	200	5850	30000