

# LONGITUDINAL CHAIN CONVEYOR – LCG



## TECHNICAL FEATURES

- Chain conveyor for wood logs feeding
- Manufacturing program for different length, width, number of chains, speed, capacity
- Heavy construction in order to absorb shocks deriving from logs fall into the conveyor
- Chains designed with scraper on the bottom side for rails cleaning.

## BENEFITS

- Excellent regularity feeding of raw wood
- Great storage volume
- Adjustable speed by frequency converter
- Fast assembling timing without weldings on site
- Rollers chain to decrease energy consumption and wear
- Low maintenance cost.

## BEST IN CLASS FOR:

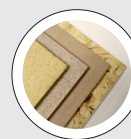

### WOOD BASED PANELS:

MDF/HDF

PB/SPB

OSB/LSB/FOSB



### PRESSED WOOD PACKAGING:

PALLET BLOCKS

PRESSED PALLETS



### PELLETS & ENERGY:

WOOD PELLETS AND  
BLACK PELLETS

GREEN FUELS AND BIOMASS

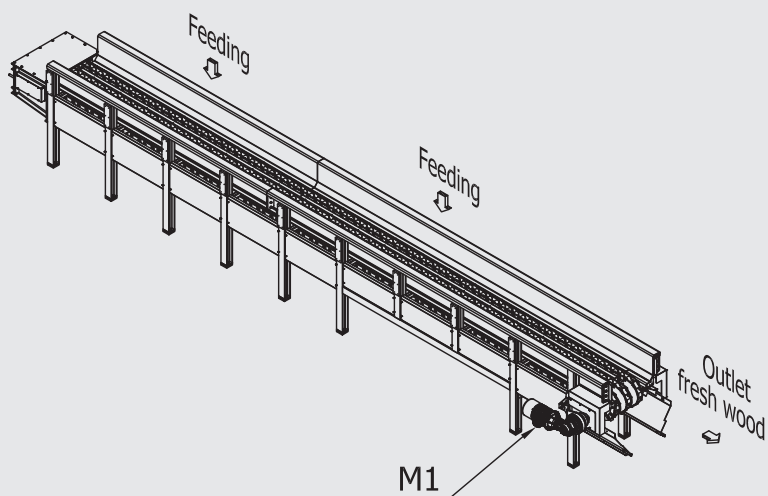
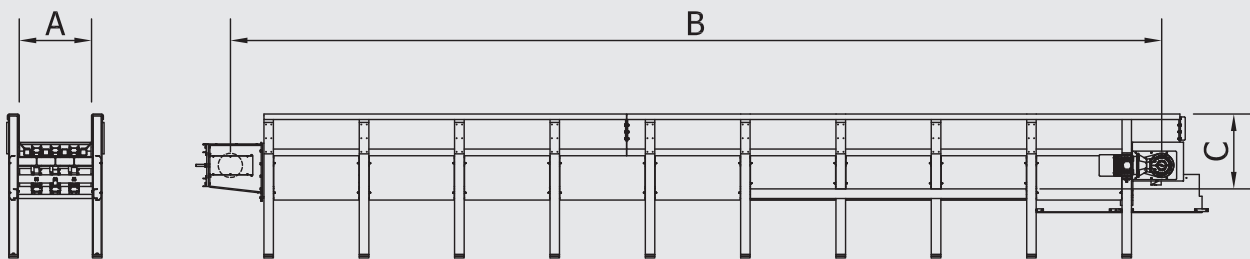

MODEL	OVERALL DIMENSIONS mm ***			
	A	B	C	N° chains
LCC**	800 ÷ 1600	6000 ÷ 24000	1150 ÷ 1650	2 ÷ 6

MODEL	CAPACITY*** m³/h	POWER kW	WEIGHT (kg)
		M1	
LCC**	***	5 ÷ 40	***

\*\*\*According to customer needs

\*\*According to dimensions