

## CIRCULAR EXTRACTORS

# LEAF SPRING

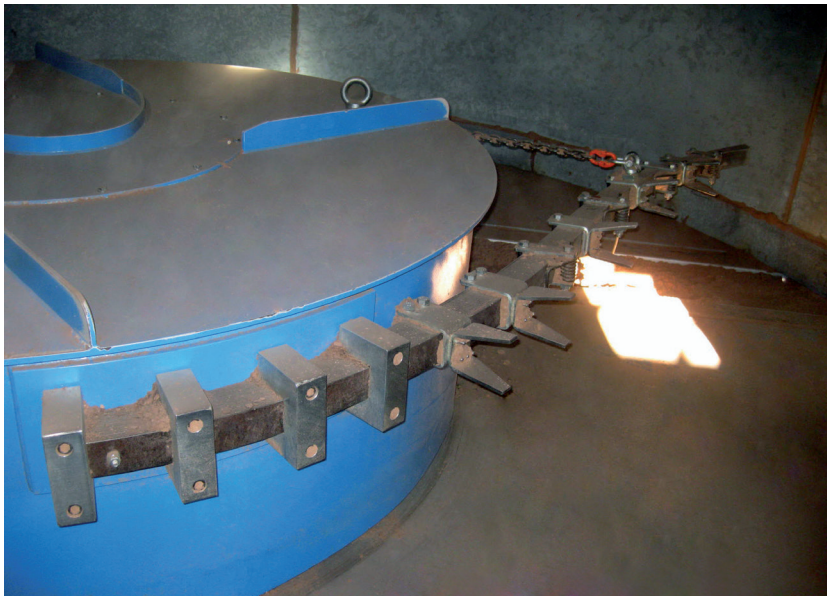

### TECHNICAL FEATURES

- Drum rotor made of welded steel plates
- Strong arms made of steel for springs
- Strong execution planetary gear box
- 2 devices to limit the movement of the arms
- Progressively variable pitch screw/s for better accuracy
- Electronic level indicator for screw empty condition
- Up to 6 different dosing screws for discharge.

### BENEFITS

- Versatile destorage-dosing system for wet or dry fractioned materials i.e. chips, sawdust, shavings, particles, dust, fiber, etc.
- Wide range of extraction capacity achieved by controlling the dosing screws with frequency converters
- High dosing accuracy from progressively variable pitch screws
- Reliable control of the silo levels
- Simple and cheap system
- High reliability
- Very low maintenance cost.

### BEST IN CLASS FOR:

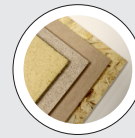

WOOD BASED PANELS:  
MDF/HDF  
PB/SPB  
OSB/LSB/FOSB  
INSULATION BOARDS



PRESSED WOOD PACKAGING:  
PALLET BLOCKS



PELLETS & ENERGY:  
WOOD PELLETS AND  
BLACK PELLETS  
LIME



WOOD RECYCLING AND  
WASTE TREATMENT:  
WASTE

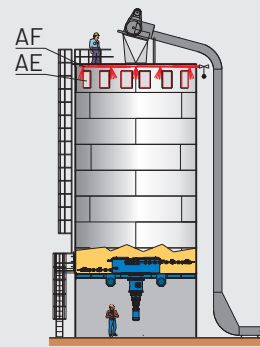
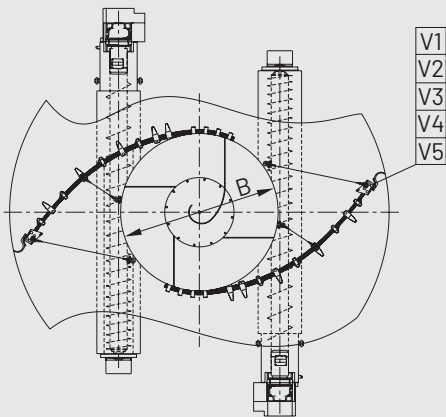
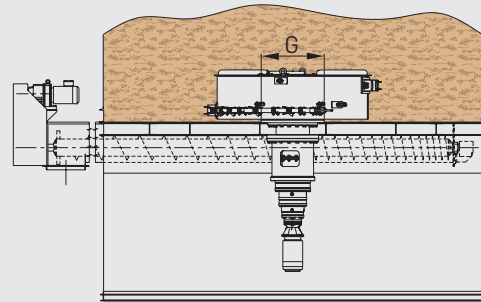
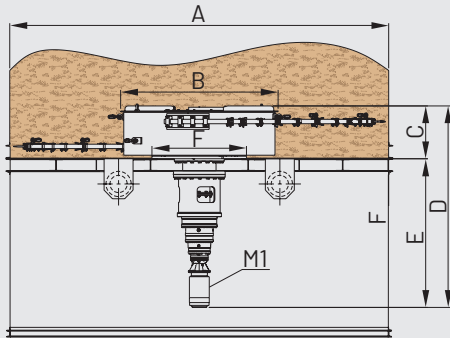

M1 = MAIN MOTOR  
 FOR DRY MATERIAL ONLY:  
 AF = FIRE-EXTINGUISHING SYSTEM  
 AE = EXPLOSION VENTS

MATERIAL TO PROCESS:  
 V1 = TRIMMING, 60-150 KG/M3  
 V2 = FIBER, 25-50 KG/M3

V3 = DUST, 1550-220 KG/M3  
 V4 = SAWDUST, 100-130 KG/M3  
 V5 = FLAKES, 100-150 KG/M3

MODEL	OVERALL DIMENSIONS mm							INSTALLED POWER kW	EXTRACTION CAPACITY m <sup>3</sup> /h	WEIGHT APPROX. kg
	A	B	C	D	E	F	G	M1		
LSE.4,5-2,0-V...	4500	2000	840	3000	2160	1500	1000	Wide range available, according to project Customer needs	According to ensiled material and extraction capacity	2300
LSE.5,0-2,0-V...	5000	2000	840	3000	2160	1500	1000			2400
LSE.5,5-2,5-V...	5500	2500	840	3200	2360	1500	1000			3300
LSE.6,0-2,5-V...	6000	2500	840	3200	2360	1500	1000			3500
LSE.6,5-2,5-V...	6500	2500	840	3400	2360	1500	1000			5300
LSE.7,0-3,0-V...	7000	3000	840	3600	2760	1500	1000			5600