

DRY MILLS  
**CENTRIFUGAL MILLS – MCG**

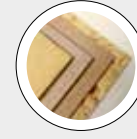

**BEST IN CLASS FOR:**



WOOD BASED PANELS:

PB/SPB

OSB/LSB/FOSB

**TECHNICAL FEATURES**

- Refining mills for dry flakes suitable for surfaces and core layers in particleboard production or multilayer LSB/OSB product
- Equipped with standard screen support ring for Conidur screen of various different hole according to the required particles
- Oil lubrication system for main bearings
- Feeding door provided with air cleaner to reject heavy pollutants.

**BENEFITS**

- Fast replacement of the ring screen
- Heavy-duty ring construction to avoid distortion and oval shaped
- Grinding track according to raw material.

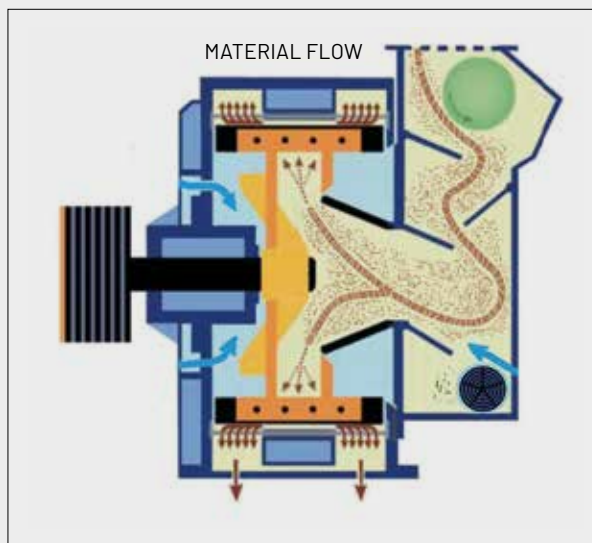
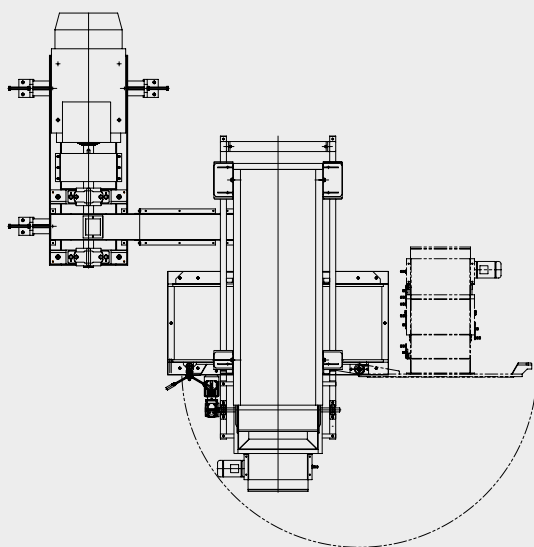
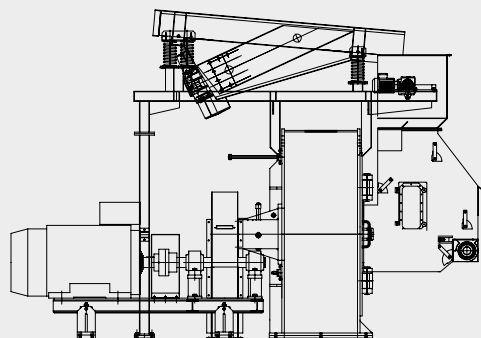
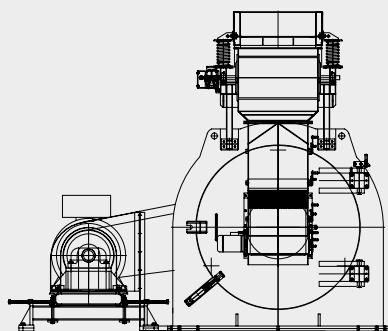

MODEL	ROTOR DIAMETER mm	GRINDING SECTORS WIDTH mm	SCREENS WIDTH mm	WEIGHT WITHOUT MAIN MOTOR kg	RECOMMENDED MOTOR kW
MCG 510	1000	225	2 x 160	3000	132/160
MCG 610	1200	225	2 x 193	4000	160/200
MCG 710	1400	265	2 x 210	4700	200/250
MCG 760	1500	288	2 x 223	5700	250/315

