

MOBILE CHIPPERS – MCU



TECHNICAL FEATURES

- Mobile system for wood chips production in different location, using a lorry for chipping machine transport
- Machine equipped with diesel engine from hp 510 up to hp 900 and relevant capacity up to 350 m³/h of chips
- Rotor equipped with three different solutions according to final production: - WPB / single knife - energy biomass / multiknives-pollutant wood / hammer.

Globus large experience in drum chipper manufacturing in wood-based panel field, has large impact in designing the mobile unit.

BENEFITS

- Low specific diesel consumption by electronic power control
- Foldable chips evacuation belt revolving and movable type
- Possibility to produce wood chips on same site, by storage 300 m³ volume, without relocating the machine.

BEST IN CLASS FOR:

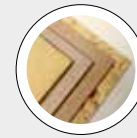

WOOD BASED PANELS:
PB/SPB
MDF/HDF



PELLETS & ENERGY:
GREEN FUELS AND BIOMASS

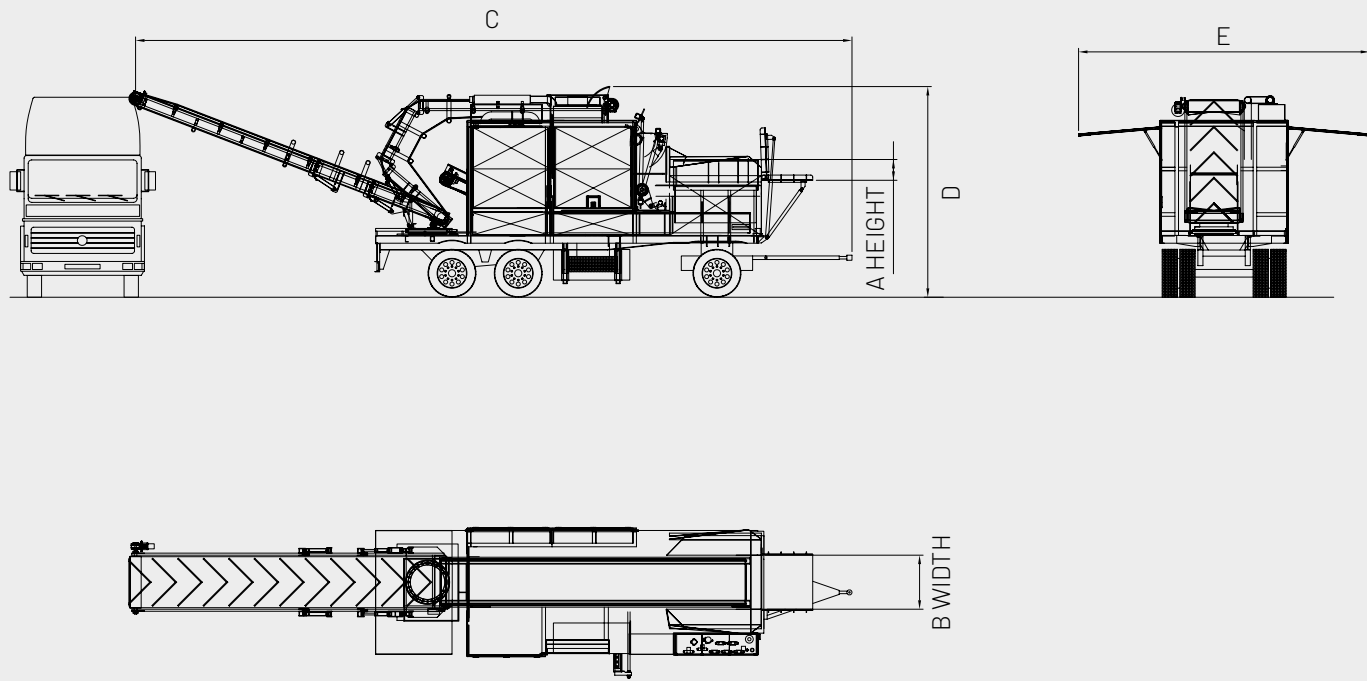

| MODEL | OVERALL DIMENSIONS mm*** | | | | |
|-------|--------------------------|---------|----------|---------|---------|
| | A | B | C | D | E |
| MCU | 400 - 500 mm | 1050 mm | 14000 mm | 4130 mm | 5700 mm |

| MODEL | CHIPPING WIDTH mm | CHIPPING HEIGHT mm | DRUM DIAMETER mm | KNIVES pcs | FEED TOOTHED ROLLERS pcs | CAPACITY m ³ /h chips | ENGINE Turbo Diesel HP |
|--------------|-------------------|--------------------|------------------|------------|--------------------------|----------------------------------|------------------------|
| MCU 40.105-M | 1050 | 400 | 1000 | 3 | 1+1 | 200 | 510 |
| MCU 50.105-M | 1050 | 500 | 1300 | 3 | 1+1 | 350 | 900 |