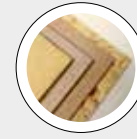

CHIPPERS

INLINE BOARD BREAKER – MPG**BEST IN CLASS FOR:**

WOOD BASED PANELS:

MDF/HDF

PB/SPB

OSB/LSB/FOSB

TECHNICAL FEATURES

MPG Board Breaker Globus is an effective solution in line to reduce rejected boards as well as cutouts of initial and final board. It is ideal for MDF, OSB and PB boards. • Reliable breaking of rejected boards with different size and thickness • Blockages are avoided thanks to the high torque power and ability in breaking at high feed speed • Reduced installed power thanks to the dual motor design • Very strong and reliable in the long term, low operating costs thanks to the simplified maintenance • Replaceable wear components to protect the essential parts of the machine • Boards infeed controlled by integrated roller way • Interchangeable cutting tools • Perforated and divided screen for an easy replacement.

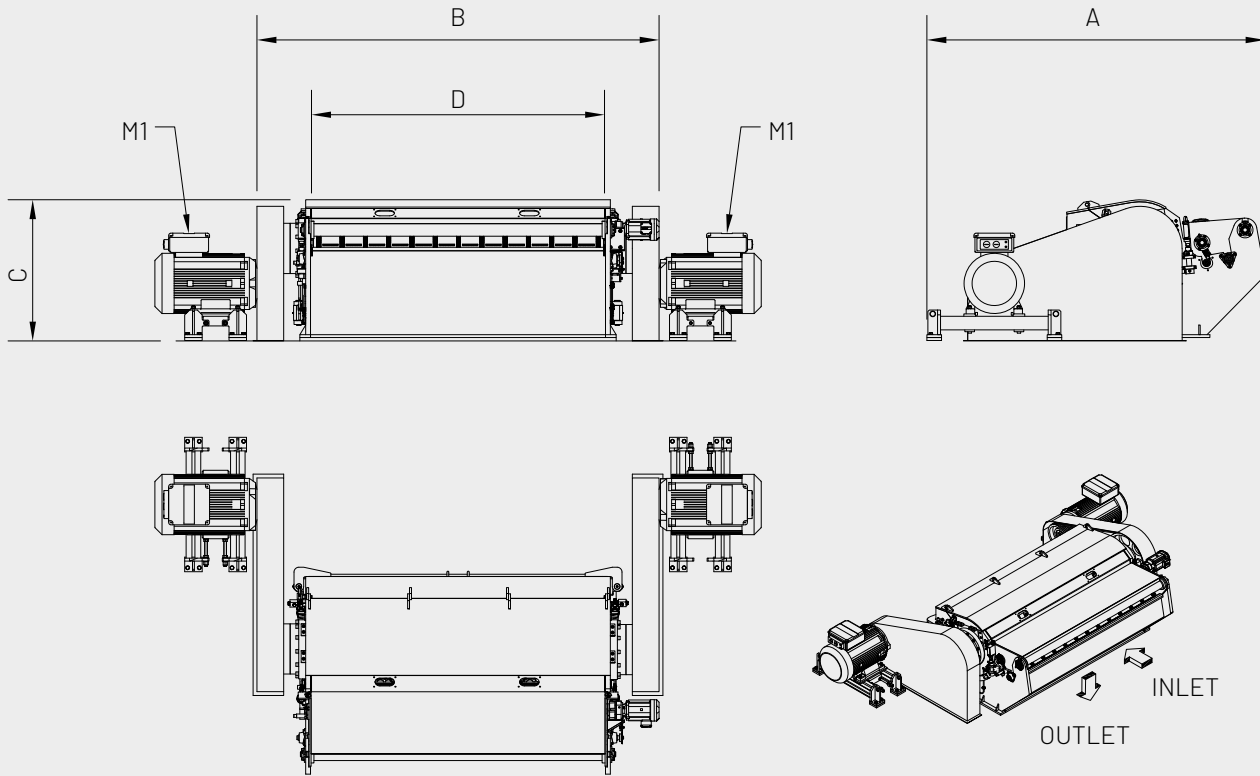

M1 = VIBRATING MOTOR

MODEL	OVERALL DIMENSIONS mm			
	A	B	C	D (infeed width)
MPG 2000	3500	3100	1500	2000
MPG 3000	3500	4100	1500	3000

MODEL	TECHNICAL DATA				
	INFEED SPEED mm/s	POWER M1 kW	ROTOR Ø mm	ROTOR LENGHT mm	WEIGHT kg
MPG 2000	100 ÷ 2000	1x250	746	2090	12000
MPG 3000	100 ÷ 2000	2x200	746	3090	15000