

DRY MILLS

CENTRIFUGAL MILLS – MSG

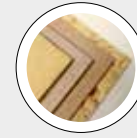

BEST IN CLASS FOR:



WOOD BASED PANELS:

PB/SPB

OSB/LSB/FOSB

TECHNICAL FEATURES

- Refining mills for dry flakes suitable to surfaces and core layers in particle-board production or multilayer LSB/OSB product
- Peculiarity of these Globus Mills for this specific application is the great advantage of being equipped with standard screen support ring for Conidur screen and with support ring for special "slotted hole" screen, which have four cutting edges
- The special design of the Mill, allows ring replacement in only 8 minutes time with a special hydraulic changing system
- Oil lubrication system for main bearings
- Feeding door provided with air cleaner to reject heavy pollutants.

BENEFITS

- Fast replacement of the ring screen grants the proper production of fine particles for the external layer according to the various boards thicknesses.

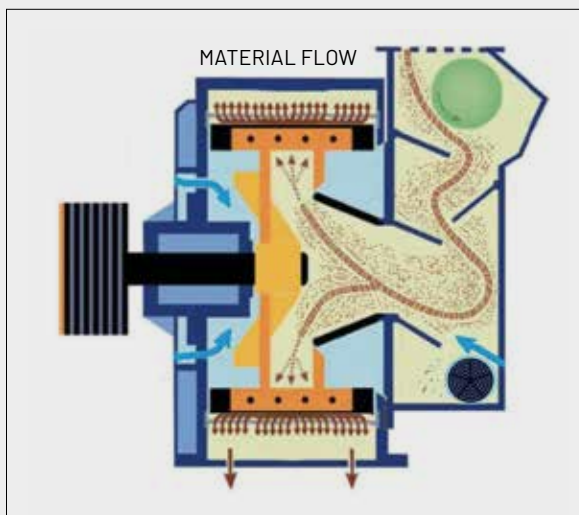
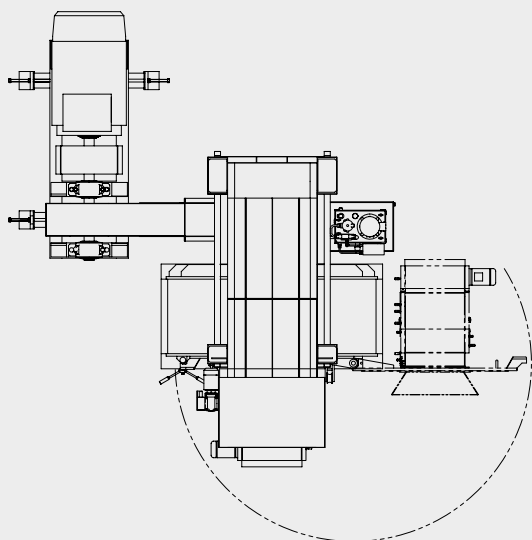
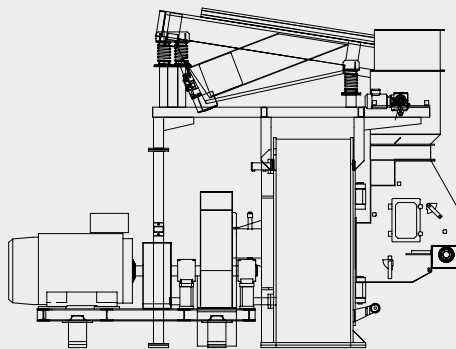
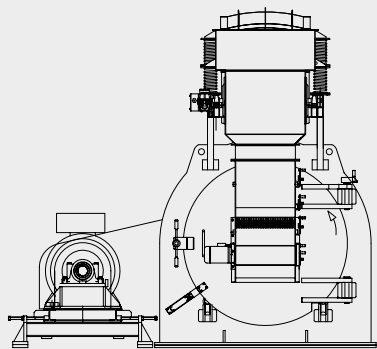

MODEL	ROTOR DIAMETER mm	GRINDING SECTORS WIDTH mm	SCREENS WIDTH mm	WEIGHT WITHOUT MAIN MOTOR kg	MAIN MOTOR kW
MSG 710	1400	265	2 x 210	4700	200/250
MSG 760	1500	288	2 X 223	5700	315/400