

## DRUM CHIPPERS – MTG



### TECHNICAL FEATURES

Over the years, Globus realized a wide range of drum chippers, with capacity from 5 up to 165 t/h bd. Machines are designed for a non stop 24 hours work (except knives changing time) granting a chipping quality according to specific customer's requirements. Main technical characteristic of Globus drum chipper:

- two different clamping system of the knives according to the various applications: mechanical system with bolts or centrifugal wedge-shaped system
- Different rotor diameter from 600 to 2400 mm and knives number from 3 to 6
- Interchangeable screens
- Screen manufactured in two halves for a quick and easy replacement (only for big machines)
- Feeding roller made hardened steel with cutting edge obtained through tooling machine
- Feeding rollers drive group equipped with double pinion/key block system plus ring feeder for powerful drive transmission and easy replacement
- Automatic rotor positioning for a safer knives changing (only for big machines)
- Driving group with hydraulic or soft-start acceleration unit
- Hydraulic ejection system of the counter-knives
- Special side door for easy screen inspection.

### BEST IN CLASS FOR:

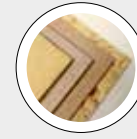

WOOD BASED PANELS:  
MDF/HDF  
PB/SPB

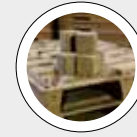

PRESSED WOOD PACKAGING:  
PALLET BLOCKS  
PRESSED PALLETS



PELLETS & ENERGY:  
GREEN FUELS AND BIOMASS  
WOOD PELLETS AND  
BLACK PELLETS

### BENEFITS

- Easy digestion of all types and sizes of wood logs and materials
- Perfect perpendicular introduction of logs grants high quality cutting and low over-size quantity
- Easy change of knives and counter-knife in order to minimize idle time
- Minimized energy consumption
- Low maintenance timing
- Minimized energy consumption
- Low maintenance timing.

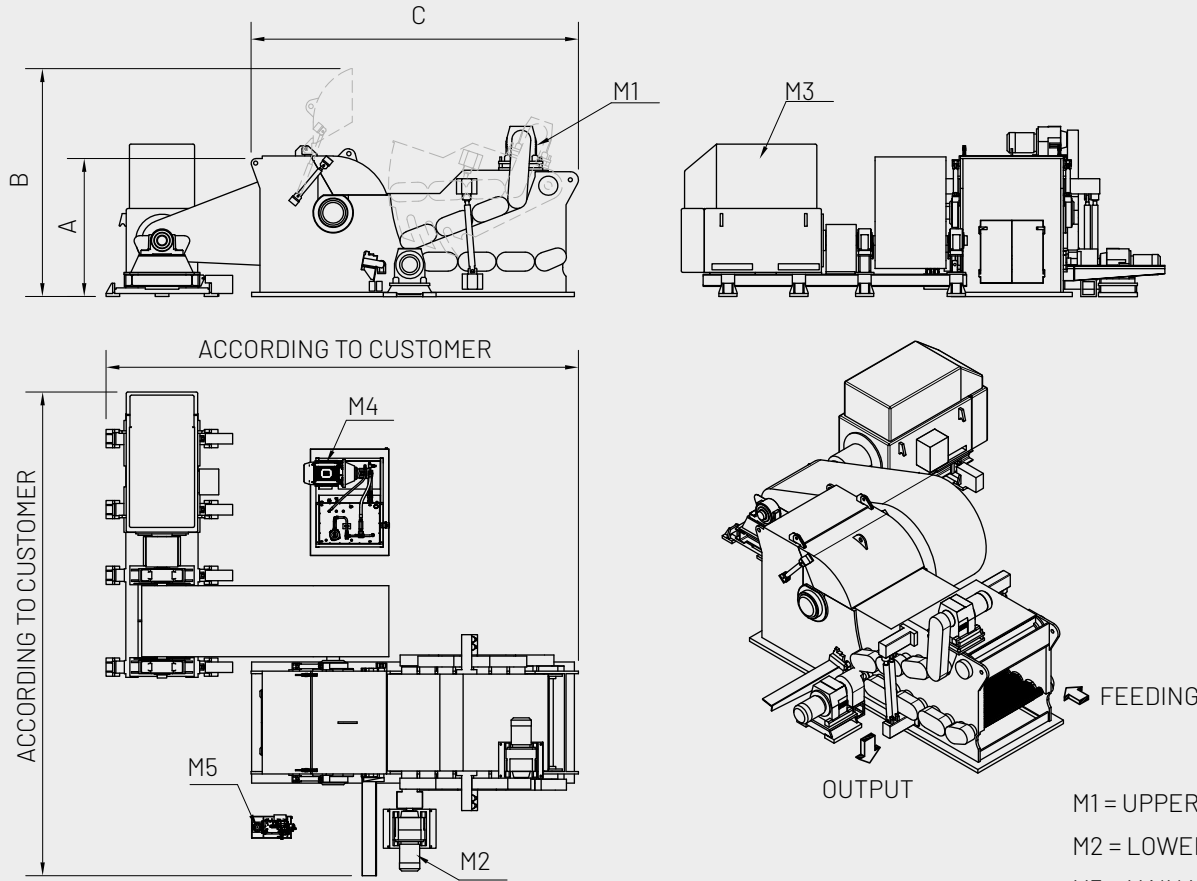

- M1 = UPPER ROLLS DRIVE
- M2 = LOWER ROLLS DRIVE
- M3 = MAIN MOTOR
- M4 = STARTER HYDR. UNIT
- M5 = SERVICE HYDR. UNIT

MODEL	OVERALL DIMENSIONS mm			MATERIAL INFEEED SECTION mm	ROTOR mm	KNIVES No.	MAIN MOTOR POWER kW	WEIGHT WITHOUT MOTOR kg	CAPACITY		
	A	B	C						t/h bd	m <sup>3</sup> /h solid	rm chips/h
Hand L SERIE											
MTG 35.065H-6R	1550	2050	2650	350x650	1000	2/3	160/200	9000	20	44	116
MTG 35.065L-6R	1350	1750	2150	350x650	800	2/3	160/200	8000	13	30	78
MTG 35.085H-6R	1750	2050	2850	350x850	1000	2/3	200/250	10000	26	58	150
MTG 35.105H-6R	1750	2050	2850	350x1050	1000	2/3	250/315	11000	31	69	179
MTG 40.065H-8R	1800	2700	3900	400x650	1300	3/4	200/250	12000	24	51	138
MTG 40.065L-6R	1800	2700	3250	400x650	1000	2/3	160/200	9000	20	44	116
MTG 40.085H-8R	2050	3300	3900	400x850	1300	3/4	250/315	14000	30	67	173
MTG 40.085L-6R	1800	2700	3250	400x850	1000	2/3	200/250	10000	26	58	150
MTG 40.105H-8R	2050	3300	3900	400x1050	1300	3/4	315/450	18000	37	82	214
MTG 40.105L-6R	1800	2700	3250	400x1050	1000	2/3	250/315	11000	31	69	179
MTG 40.125H-8R	2050	3300	3900	400x1250	1300	3/4	400/500	21000	44	98	254
MTG 50.085H-10R	2500	3800	5000	500x850	1600	3/4/5	315/450	24000	40	89	231
MTG 50.085L-8R	2300	3600	4800	500x850	1300	3/4	250/355	14000	30	67	173
MTG 50.105H-10R	2500	3800	5000	500x1050	1600	3/4/5	400/500	26000	50	111	289
MTG 50.105L-8R	2300	3600	4800	500x1050	1300	3/4	315/450	18000	37	82	214
MTG 50.125H-10R	2500	3800	5000	500x1250	1600	3/4/5	500/630	28000	60	133	347
MTG 50.125L-8R	2300	3600	4800	500x1250	1300	3/4	400/500	21000	44	98	254
MTG 50.145H-10R	2500	3800	5000	500x1450	1600	3/4/5	500/750	34000	65	145	377
MTG 60.105L-10R	2500	3800	5000	600x1050	1600	3/4/5	400/500	26000	50	111	289
MTG 60.125L-10R	2500	3800	5000	600x1250	1600	3/4/5	500/750	32000	60	133	347
MTG 60.145L-10R	2500	3800	5000	600x1450	1600	3/4/5	500/750	37000	65	145	377
MTG 85.105H-13R	3000	4500	6000	850x1050	2000	4/5/6	750/1000	45000	80	178	462
MTG 85.125H-13R	3000	4500	6000	850x1250	2000	4/5/6	1000/1200	50000	95	211	549
MTG 85.145H-13R	3000	4500	6000	850x1450	2000	4/5/6	1000/1200	60000	110	244	636
MTG 105.145L-15R	3400	4900	6500	1050X1450	2200	4/5/6	1000/1400	70000	130	289	751
MTG 105.145H-15R	3400	4900	6500	1050X1450	2400	4/5/6	1200/1400	75000	140	311	809
MTG 105.165L-15R	3400	4900	6500	1050x1650	2200	4/5/6	1200/1600	82000	150	333	867
MTG 105.165H-15R	3400	4900	6500	1050x1650	2400	4/5/6	1200/1600	88000	160	356	924