

FERROUS METALS REMOVERS  
**OVERBELT MAGNETS – OBM**

FOR CHIPS, SAWDUST AND PARTICLES



#### TECHNICAL FEATURES

- Strong magnetic plate (HG) • Deferrizing overbelt • Drive system • Assembled unit complete of containment box.

#### BENEFITS

- High efficiency and reliability • Removal of ferrous pollutants from chips, sawdust and particles, e.g. during transport with belt conveyors • Simple installation • Low maintenance.

#### BEST IN CLASS FOR:



WOOD BASED PANELS:  
 MDF/HDF  
 PB/SPB  
 OSB/LSB/FOSB  
 INSULATION BOARDS



PRESSED WOOD PACKAGING:  
 PALLET BLOCKS



PELLETS & ENERGY:  
 WOOD PELLETS AND  
 BLACK PELLETS  
 LIME



WOOD RECYCLING AND  
 WASTE TREATMENT:  
 WASTE

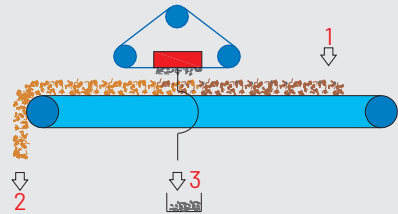
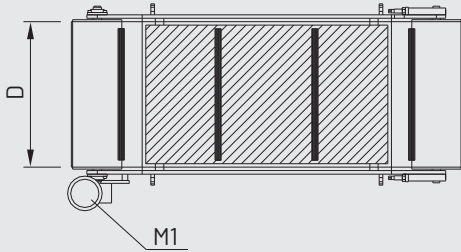
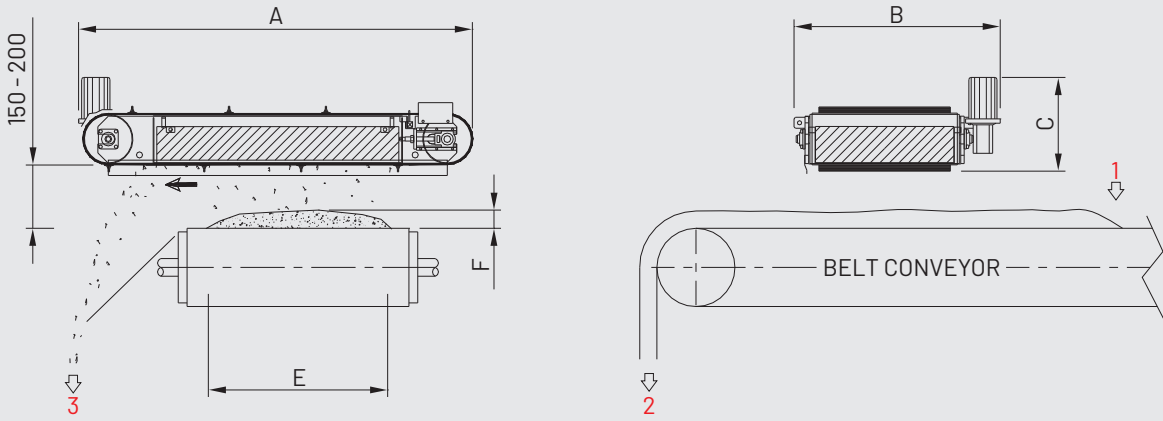

1 = POLLUTED MATERIAL    3 = FERROUS METAL REMOVED  
 2 = CLEANED MATERIAL    M1 = MAIN MOTOR



MODEL	OVERALL DIMENSIONS mm			
	A	B	C	D
OBM.100/135-HG-VHG	2425	1490	684	1050
OBM.100/175-HG-VHG	2820	1490	682	1050
OBM.100/220-HG-VHG	3270	1490	682	1050
OBE.90/100	2374	1462	810	950
OBE.90/120	2574	1462	810	950
OBE.90/140	2774	1462	810	950
OBE.90/175	3124	1462	780	950

MODEL	CAPACITY BULK CHIPS			INSTALLED POWER kW		WEIGHT APPROX. kg
	m <sup>3</sup> /h	E mm	F mm	M1 MAIN MOTOR	M2 ELECTROMAGNET	
OBM.100/135-HG-VHG	Assessable according to (E), (F) and conveying speed	< 1000	50 - 80	2,2	-	2350
OBM.100/175-HG-VHG		< 1400	50 - 80	2,2	-	3000
OBM.100/220-HG-VHG		< 1900	50 - 80	2,2	-	3800
OBE.90/100		< 800	80 - 120	2,2	4,2	2870
OBE.90/120		< 1000	80 - 120	2,2	4,5	3350
OBE.90/140		< 1200	80 - 120	2,2	5	3840
OBE.90/175		< 1600	80 - 120	2,2	7,5	4810