

RE-CHIPPERS – RMG



TECHNICAL FEATURES

- This specific machine, is able to process small rejected wood materials such as barks or forestry waste and also the wood over-size coming from others size of reduction machineries
- Basic concept of this machine is the same of all other Globus drum chipper machines, except for the top gravity feeding system of the inlet material
- Bigger machines are equipped with hydraulic upper hood lifting and counter knife ejection.

BENEFITS

- Easy digestion of all types of wood materials
- Easy change of knives
- Lateral counter-knife ejection on sliding guide
- Minimized energy consumption
- Low maintenance cost.

BEST IN CLASS FOR:

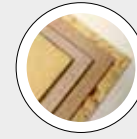

WOOD BASED PANELS:
MDF/HDF
PB/SPB
OSB/LSB/FOSB

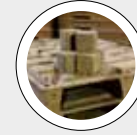

PRESSED WOOD PACKAGING:
PALLET BLOCKS
PRESSED PALLETS



PELLETS & ENERGY:
GREEN FUELS AND BIOMASS
WOOD PELLETS AND
BLACK PELLETS

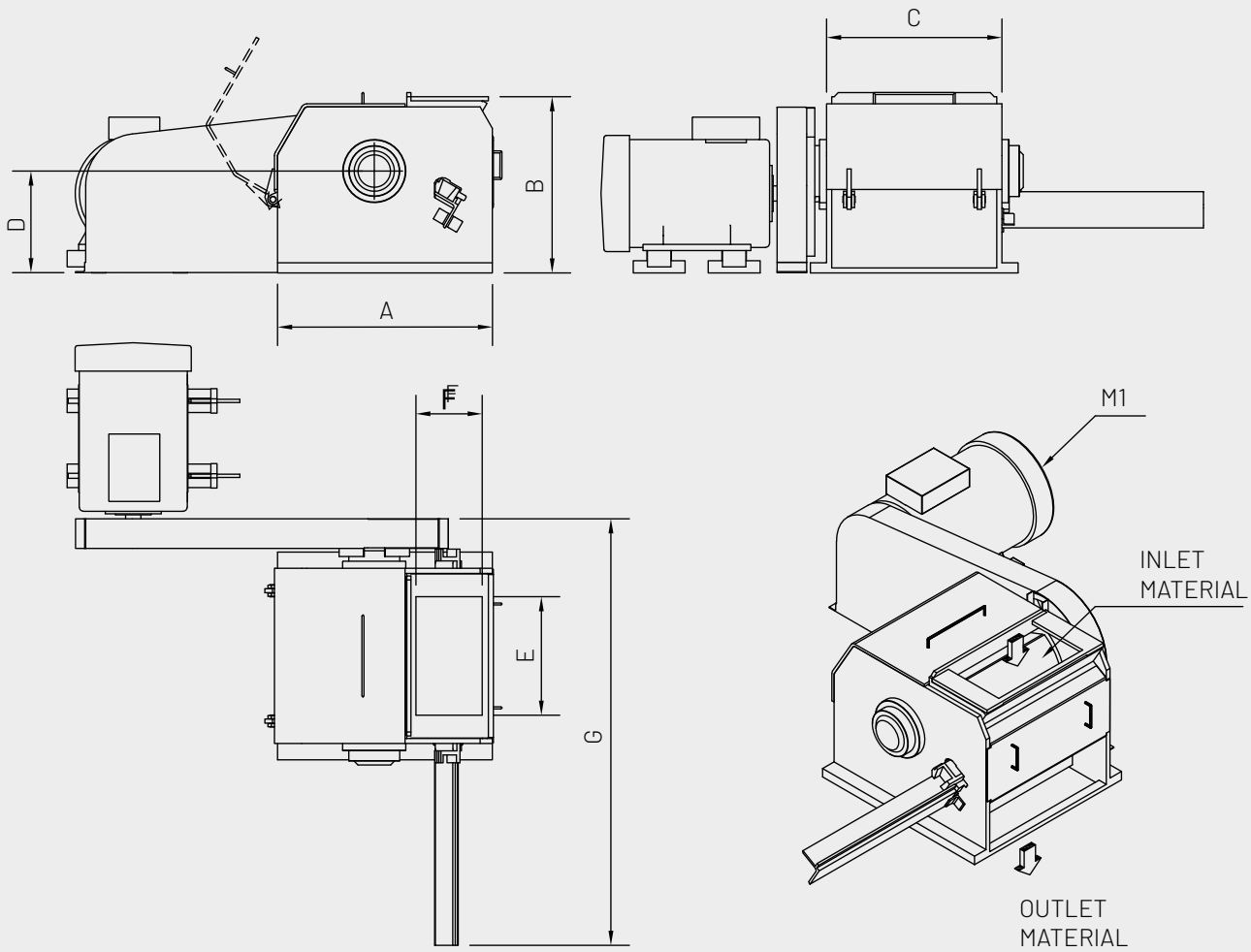

MODEL	OVERALL DIMENSIONS mm ***							
	A	B	C	D	E	F	G	N° knives
RMG 600.75	1050	870	850	500	750	350	1200	2 ÷ 3
RMG 600.100	1050	870	1100	500	1000	500	2500	2 ÷ 3
RMG 800.75	1250	1120	850	600	750	350	1200	2 ÷ 4
RMG 800.100	1250	1120	1100	600	1000	500	2500	2 ÷ 4
RMG 1200.75	1650	1470	850	800	750	500	1200	2 ÷ 5

MODEL	CAPACITY**** m ³ /h chips	POWER kW		WEIGHT kg
		M1		
RMG 600.75	10 ÷ 20	30 ÷ 200		1500 ÷ 2700
RMG 600.100	13 ÷ 26			
RMG 800.75	30 ÷ 60			
RMG 800.100	40 ÷ 80			
RMG 1200.75	50 ÷ 125			

***According to customer needs

****According to raw material size and density