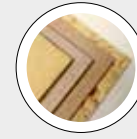

DISK STRANDER

SDG**BEST IN CLASS FOR:**

WOOD BASED PANELS:

PB/SPB

OSB/LSB/FOSB

TECHNICAL FEATURES

- The DISK STRANDER is a machine for STRAND and high quality flakes production
- Knives and Counter knives with various angles
- Inserts modularity that allow to obtain widely configurable lengths and widths product
- Automated and assisted hydraulic cutting process
- Adaptability for the OSB panels production and / or low density PB.

BENEFITS

- Automatic advance control
- Cutting disc long operating life
- Hydraulic start
- High dimensional strand control accuracy
- Constant cutting with different logs sizes
- Disposable knife or grinding knife version.

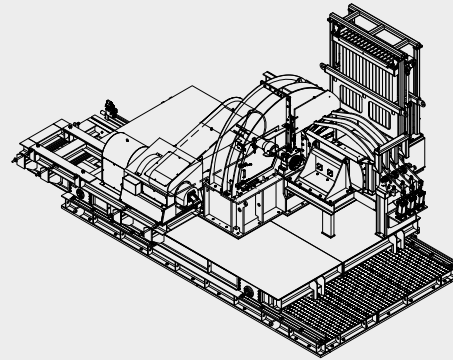
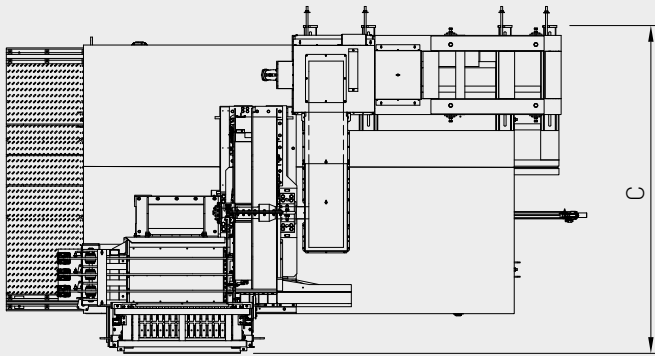
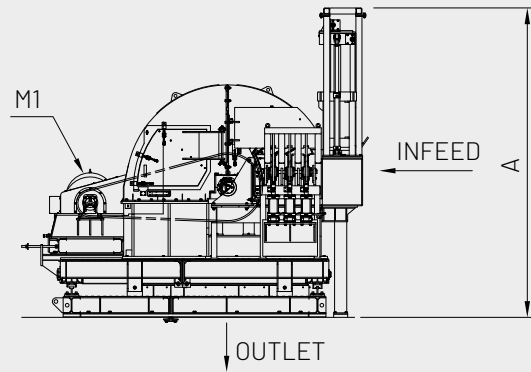
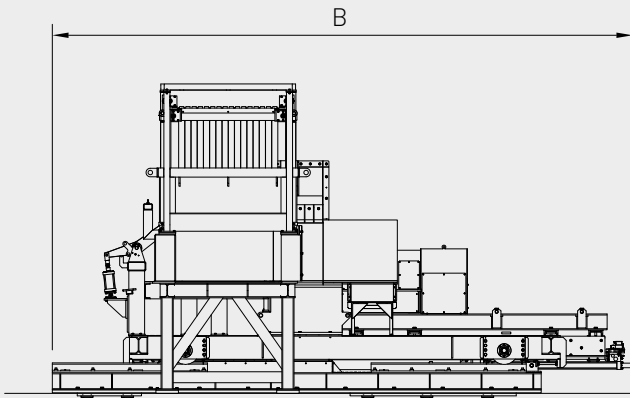

M1 = VIBRATING MOTOR

MODEL	TECHNICAL DATA				
	ROTOR DIAMETER mm	KNIFE LENGHT mm	KNIVES N°	TOTAL WEIGHT kg	CAPACITY t/h
SDG 30.300	3000	940	30 ÷ 30	63500	up to 30

MODEL	OVERALL DIMENSIONS mm		
	A	B	C
SDG 30.300	5140	9360	5380

MODEL	POWER kW	WEIGHT kg
	M1	
SDG 30.300	630 ÷ 900	5000 ÷ 8500