

STEPPER SCREEN

PATENTED



TECHNICAL FEATURES

- New patented screening principle from PAL
- Self-cleaning screening system
- High production throughput, adjustable by inverter
- One machine only combining a ballistic and aeraulic starscreening
- Hydraulically adjustable machine inclination.

BENEFITS

- (Easily) settable selection size
- Small footprint machinery
- Wide range of operation according to the material type
- Low maintenance costs.

BEST IN CLASS FOR:

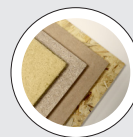

WOOD BASED PANELS:
MDF/HDF
PB/SPB
OSB/LSB/FOSB
INSULATION BOARDS



PRESSED WOOD PACKAGING:
PALLET BLOCKS



PELLETS & ENERGY:
WOOD PELLETS AND
BLACK PELLETS
LIME



WOOD RECYCLING AND
WASTE TREATMENT:
WASTE

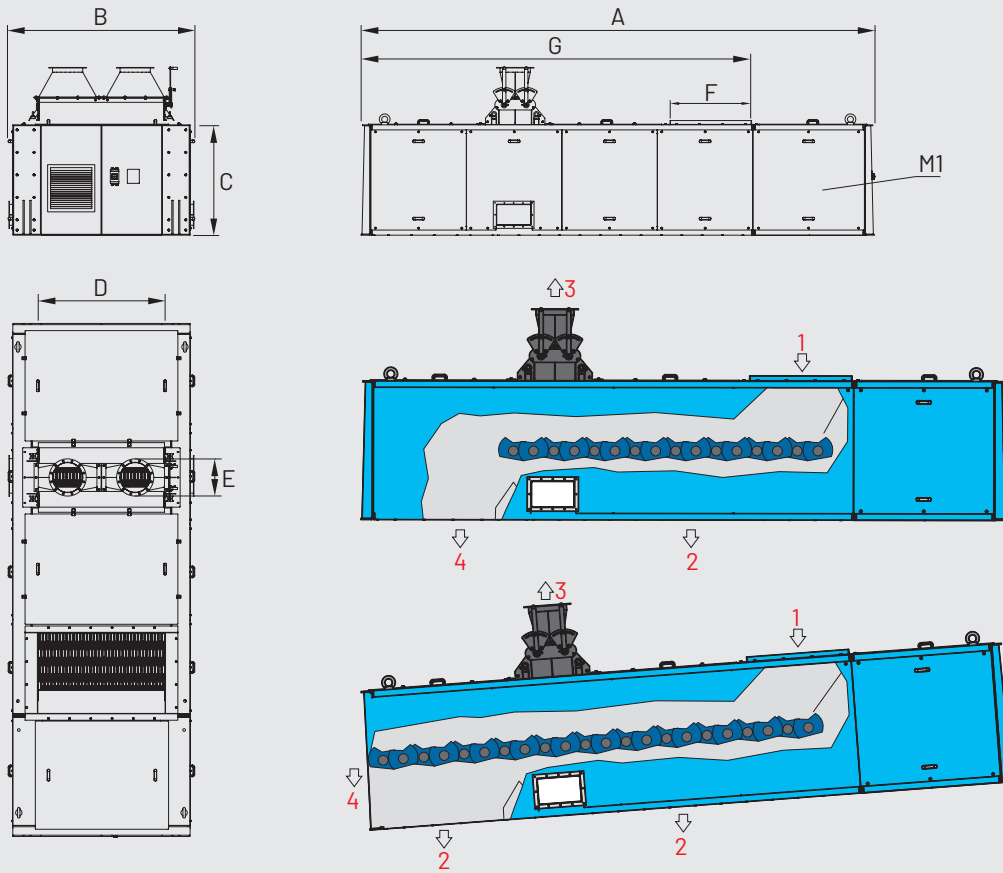

1 = INFEED MATERIAL
2 = FRACTIONS

3 = LIGHT MATERIAL (OPTION)
4 = OVERSIZE / FILAMENTOUS MATERIAL

M1 = MAIN MOTOR

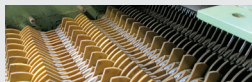

2

4

MODEL	OVERALL DIMENSIONS mm							CAPACITY	TOTAL INSTALLED POWER kW
	A	B	C	D	E	F	G		
STS.1-4500-1500	6045	2200	1300	1500	1x280	950	4500	According to type of material, gap and number of rolls	7,5-15 According to number of rolls
STS.1-4000-1500	5545	2200	1300	1500	1x280	950	4000		
STS.1-3200-1500	3200	2200	735	1500	-	600	3200		