

TIGER

FROM URBAN FOREST TO READY CHIPS

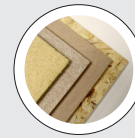

BEST IN CLASS FOR:



WOOD BASED PANELS:
PB/SPB



PRESSED WOOD PACKAGING:
PALLET BLOCKS
LIME



WOOD RECYCLING AND
WASTE TREATMENT:
WASTE

TECHNICAL FEATURES

- U-feeder based on vibrating channel or long chain-plate conveyor and terminal toothed rollers
- Swivelling introduction head with toothed rollers
- High speed rotor equipped with very strong hammers
- Digesting chamber equipped with openable inspection gates and inner wearproof protections
- Front flaps to reject indigestible materials such as large metallic contaminants, etc.
- Very big strong hammers
- Outfeed screen to control the size of crushed chips.

BENEFITS

- Easy digestion of all urban forest material, bulky or pre-crushed
- Easy digestion of pollutants such as minerals, stones, plastics, glass, etc.
- Elimination of bigger and tougher heavy pollutants
- Very low specific energy consumption and maintenance.

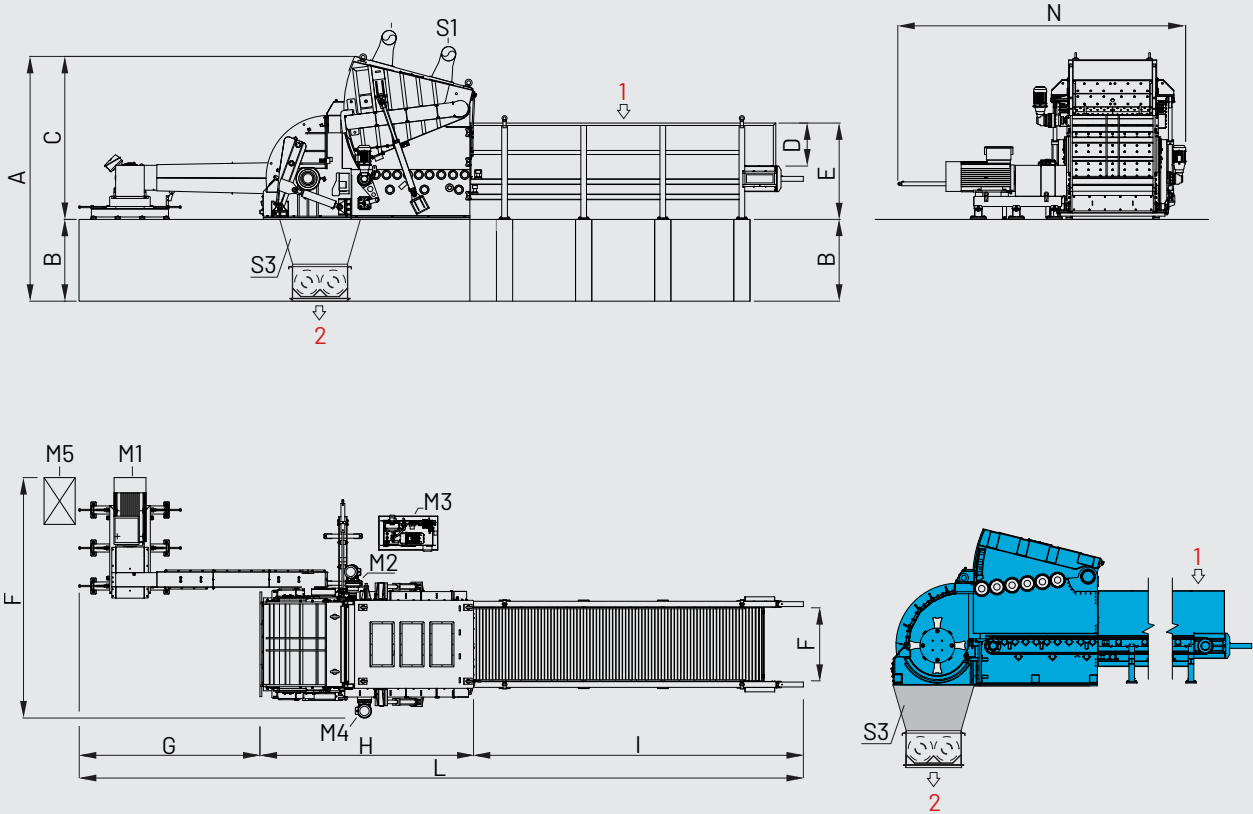

MODEL	OVERALL DIMENSIONS mm											
	A	B	C	D	E	F	*G	H	I	L	M	N
TIGER 150-70C	4830	1800	3030	1080	2260	3600	3620	5390	6653	15663	1500	6570
TIGER 180-90L	4128	765	3363	1080	2257	7881	3565	4487	6653	14705	1830	5546
TIGER 210-90	4780	765	4015	1080	2257	7881	3565	5145	10170	19835	2000	7072

*Variable according to motor size

MODEL	INLET SECTION mm			ROTOR DIAMETER mm	CAPACITY** t/h		INSTALLED POWER kW				
	WIDTH	HEIGHT	HEIGHT OF MATERIAL		BULKY MATERIALS***	PRE-CRUSHED MATERIALS****	M1**	M2	M3	M4	M5
TIGER 150-70C	1550	700	400	1200	15-20	30-40	400-500	15	5,5	9,2	55
TIGER 180-90L	1800	1350	900	1400	25-35	45-65	400-500	15	5,5	11	75
TIGER 210-90	2000	1350	900	1400	30-40	50-70	710-1000	15	7,5	11	75

*Based on pre-crushed material, bulk density 150 kg/m³ bd, moisture content < 25% bd

**According to type, bulk density and moisture content of material to crush

MODEL	EXHAUST SUCTION S1			EXHAUST SUCTION S2		
	SUCTION m ³ /h	AIR SPEED m/s	SUCTION PRESSURE Pa	SUCTION m ³ /h	AIR SPEED m/s	SUCTION PRESSURE Pa
TIGER 150-70C	2x2570	29	1000	4000	29	1000
TIGER 180-90L	2x10000	29	1000	10000	29	1000
TIGER 210-90	2x10000	29	1000	10000	29	1000