

# WIND SIFTER SINGLE MACHINES



## TECHNICAL FEATURES

- Classifying chamber complete with: infeed system (from model 3.1) - horizontal fluidizing screen - comb system for moving thick particles and improving separation of heavy pollutants - zigzag channels - suction hopper connected to the cyclone - outfeed device for rejected particles - discharge system for heavy pollutants • Fan • Cyclone for accepted particles • AF - Fire extinguishing system • AE - Explosion protection system.

## BENEFITS

- High efficiency in classification • The turbulence generated by the zigzag channels ensures the thick-large (jumbo) particles to drop (that are improperly sucked and classified as accepts by other selectors) • Selection limit freely adjustable • Unbeatable removal of heavy pollutants • Highly reliable • Low maintenance.

## BEST IN CLASS FOR:



WOOD BASED PANELS:  
MDF/HDF  
PB/SPB



PRESSED WOOD PACKAGING:  
PALLET BLOCKS



PELLETS & ENERGY:  
WOOD PELLETS AND  
BLACK PELLETS  
LIME



WOOD RECYCLING AND  
WASTE TREATMENT:  
WASTE

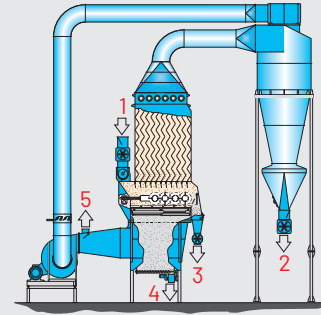
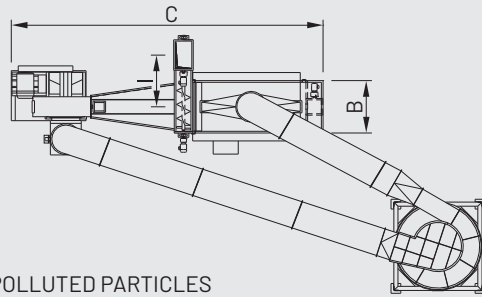
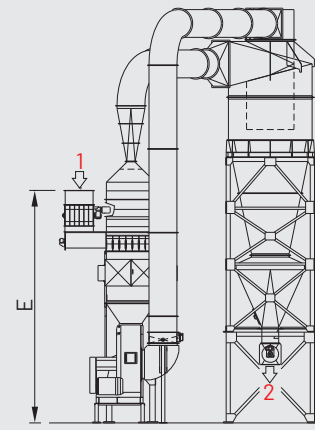
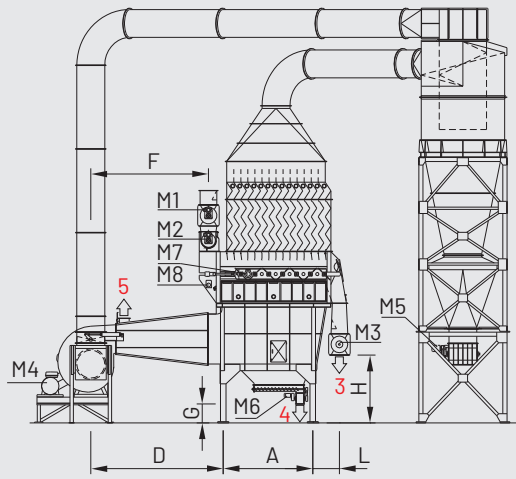

- 1= POLLUTED PARTICLES
- 2= ACCEPTS, CLEANED THIN PARTICLES
- 3= REJECTS, THICK PARTICLES
- 4= SAND / HEAVY POLLUTANTS
- 5= EXHAUST AIR
- M1= FEEDING SCREW

- M2 = ROTARY VALVE IN
- M3 = ROTARY VALVE REJECT EXTRACTION
- M4 = FAN DRIVE

- M5 = ROTARY VALVE OUT
- M6 = ROTARY VALVE SAND EXTRACTION
- M7 = COMBS ROTATION
- M8 = COMBS OSCILLATOR

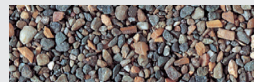
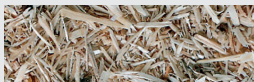

2

3

4

MODEL	OVERALL DIMENSIONS mm									
	A	B	C	D	E	F	G	H	I	L
WS.1,6	1940	806	8085	3161	7328	2911	1200	2650	-	877
WS.2,0	2290	806	8439	3161	7569	2811	1200	2650	-	877
WS.2,5	2290	1006	8439	3161	7564	2811	1200	2650	-	877
WS.3,1	2250	1256	8796	3350	8234	2910	1200	2660	1622	897
WS.3,5	2250	1406	8839	3450	8234	2980	1200	2500	1368	897
WS.4,0	2450	1456	9098	3450	8355	3007	1200	2600	1372	956
WS.4,5	2450	1626	9288	3550	8383	3082	1200	2600	1487	956
WS.5,3	3212	1506	10049	3550	9023	3023	1200	2800	1547	955
WS.6,2	3212	1756	10049	6550	8978	2973	1200	2600	1922	955
WS.7,5	3212	2106	10554	3550	9070	2965	1200	2800	1775	955
WS.8,3	3717	2260	11150	4070	9215	3485	1200	2600	2150	955
WS.9,0	3717	2260	11150	4070	9215	3485	1200	2600	2150	955
WS.10,0	3717	2500	12249	4515	9450	3931	1047	2500	2477	960
WS.12,5	3717	3100	12249	4515	9450	3960	1047	2500	2477	960

Cyclone and pipe have to be sized and located according to the process data for processed material and outfeed position

MODEL	CAPACITY t/h				INSTALLED POWER kW								EXHAUST AIR m³/h	WEIGHT* APPROX. kg
	S.L. DRY	C.L. DRY	OVERSIZE DRY	RECY MIX	M1	M2	M3	M4	M5	M6	M7	M8		
WS.1,6	2,9	4,8	5,8	5,6	-	3,0	1,5	Information available according to processed material and cyclone distance.	3,0	-	1,5	-	Information available according to processed material.	6000
WS.2,0	3,6	6,0	7,2	7,0	-	3,0	1,5		3,0	0,75	1,5	-		7550
WS.2,5	4,5	7,5	9,0	8,8	-	3,0	1,5		3,0	0,75	1,5	-		9000
WS.3,1	5,6	9,3	11,2	10,9	4,0	3,0	3,0		3,0	0,75	1,5	-		10500
WS.3,5	6,3	10,5	12,6	12,3	4,0	4,0	3,0		4,0	0,75	1,5	-		11000
WS.4,0	7,2	12,0	14,4	14,0	4,0	4,0	3,0		4,0	0,75	2,2	0,55		12000
WS.4,5	8,1	13,5	16,2	15,8	4,0	4,0	3,0		4,0	0,75	2,2	0,55		12500
WS.5,3	9,5	15,9	19,1	18,6	4,0	4,0	3,0		4,0	0,75	2,2	0,55		13000
WS.6,2	11,2	18,6	22,3	21,7	7,5	5,5	3,0		5,5	0,75	2,2	0,55		14000
WS.7,5	13,5	22,5	27,0	26,3	7,5	5,5	4,0		5,5	0,75	2,2	0,55		14500
WS.8,3	14,9	24,9	29,9	29,1	7,5	5,5	4,0		5,5	0,75	2,2	0,55		15000
WS.9,0	16,2	27,0	32,4	31,5	7,5	5,5	4,0		5,5	0,75	2,2	0,55		15800
WS.10,0	18,0	30,0	36,0	35,0	9,2	5,5	4,0		5,5	0,75	4,0	0,75		20000
WS.12,5	22,5	37,5	45	43,7	9,2	5,5	4		5,5	0,75	4	0,75		25500

\*Weight without piping and cyclone