

Laboratory Equipment Catalogue

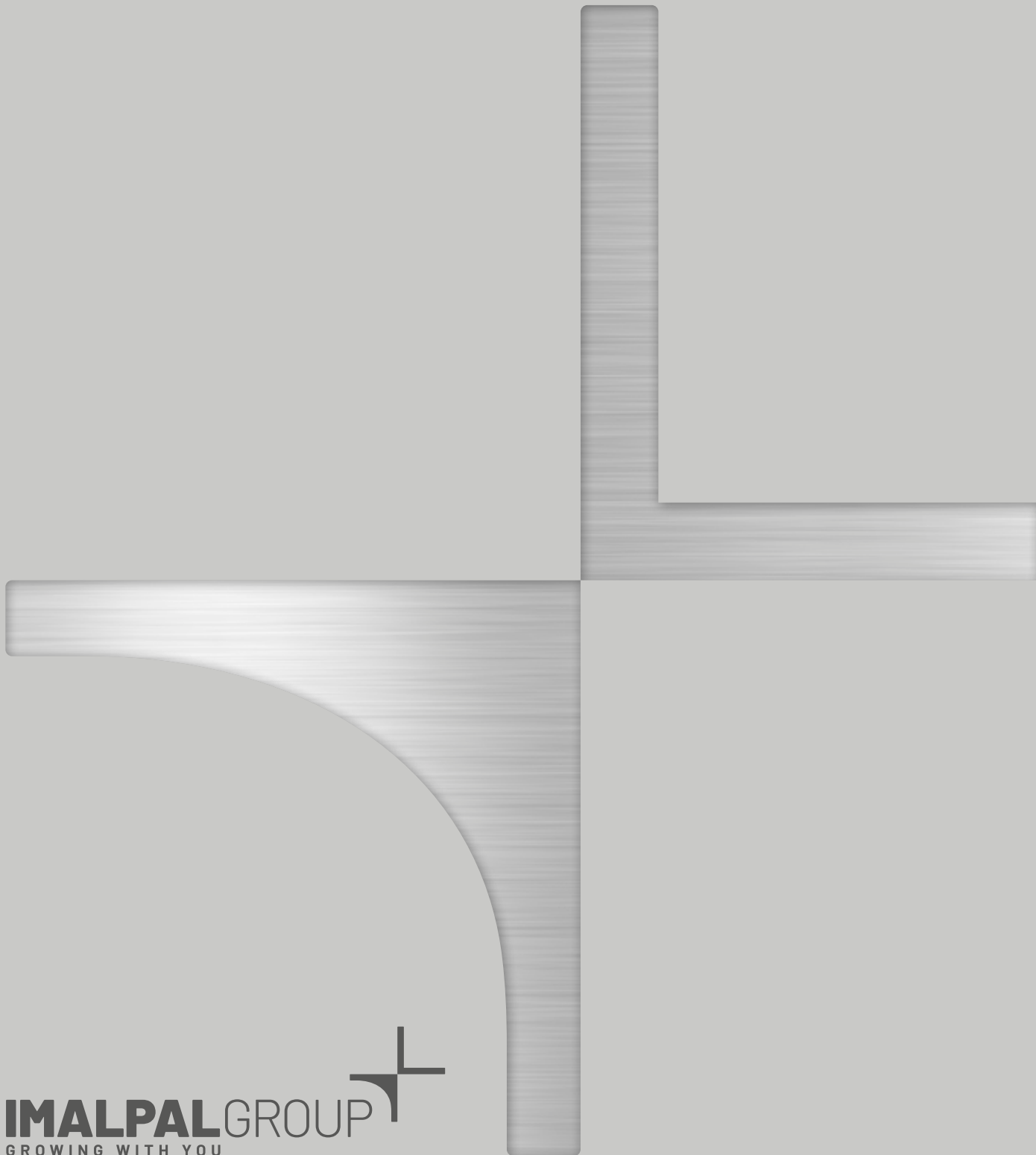

Laboratory Equipment Catalogue

Leading the way



Manufactures and supplies equipment and systems for the production and processing of PB/SPB, MDF/HDF, OSB/LSB/FOSB panels, insulation boards, pellets, pallet blocks and pressed wood-based products in general.

In addition to the supply of complete, brand new and fully refurbished production lines, IMAL is a leading manufacturer of glue dosing and blending systems as well as suppliers of the most innovative on-line and laboratory quality control devices and its products are found in virtually all the production plants around the world. Its target each year is to optimize the production process with the most up-to-date and advanced technology.

SMARTLAB The all in one solution

A full range of laboratory equipment with over 50 testing units including surface density analysers, different kinds of moisture meter systems, optical technology for detecting the particle size of chips and fibre, density profilers and automatic cutting unit.

The laboratory quality control systems are able to conduct all kinds of mechanical, chemical and quality tests to all international standards, to ensure that maximum performance is achieved from the boards produced.



Imal, Modena



Laboratory Equipment

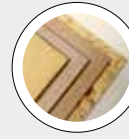

WOOD BASED
PANELS

	<i>page number</i>	PB/SPB	MDF/HDF	OSB/LSB/FOSB	INSULATION BOARDS	PLYWOOD
IB800 - IBX800 - LABLOCK	6	•	•	•		•
SW200 & BT200	8	•	•	•		
DPX400 e DPX400-LTE	10	•	•	•		
GA300	12	•	•	•		
FIBERCAM100 - SCREENCAM 100	14	•	•			
VU200	16	•	•	•		
VM100	17	•	•	•		
LS300/400	18	•	•	•		
GEL TIMER	20	•	•	•		
LABFORMER100	22	•	•			
PL100	24	•	•	•		
LGB	26	•	•	•		
UM3000	28	•	•	•		
UM2000-LTE	30	•	•	•		
UC950	32	•	•			
SMC200	34	•	•	•		•
LABROUGHNESS	36	•	•			

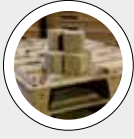

PRESSED WOOD PACKAGING

• PALLET BLOCKS

PRESSED PALLETS

STRINGERS & BEAMS



PELLETS & ENERGY

WOOD PELLETS AND BLACK PELLETS

GREEN FUELS AND BIOMASS

THERMAL AND ELECTRIC ENERGY

DRYING

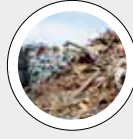

WOOD RECYCLING AND WASTE TREATMENT

WOOD RECYCLING

SLUDGE RECYCLING

PLASTIC RECYCLING

CUSTOMIZED SOLUTIONS FOR RECYCLING

•

•

BOARD PROPERTY TESTER IB800 – IBX800 – LABLOCK

TO CARRY OUT LABORATORY TESTS FOR BOARD QUALITY CONTROL



Density profile analyzer
in the IBX800 version

The IB800 laboratory testing machine has been designed to test the quality and mechanical characteristics of wood-based panels (particleboard, MDF, OSB, plywood and pallet blocks) and to then process the results obtained. The IB800 combines simplicity of use with safe and reliable operation thanks to a microprocessor which controls the data measurement process and file management. It comes complete with a set of accessories to conduct all the tests in full compliance with today's standards (European standards, North American standards and others upon request).

TESTS PERFORMED IN COMPLIANCE WITH EN EUROPEAN STANDARDS

• Dimensions (EN 325) • Density (EN 323) • Tensile strength (EN319) • Surface soundness (EN311) • Screw holding (EN320) • Bending strength and Modulus of Elasticity (EN310).

OTHER TESTS FOR WHICH IT IS POSSIBLE TO COLLECT AND STORE DATA IN THE IB800 DATABASE, IN CONJUNCTION WITH OTHER EQUIPMENT:

• Swelling and absorption (EN317) • Cyclic test in wet conditions (EN321) • Moisture content (EN322) • Boil test (EN1087-1) • Formaldehyde content (EN ISO 12460-5 / 12460-3) • Surface absorption (EN382) • Dimensional changes according to humidity (EN318) • PB, MDF and OSB moisture values • Particle / fiber screening test • Sand content • Hardness.

BEST IN CLASS FOR:

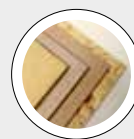

WOOD BASED PANELS:

PB/SPB
OSB/LSB/FOSB
MDF/HDF
PLYWOOD

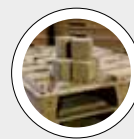

PRESSED WOOD PACKAGING:

PALLET BLOCKS

It is possible to supply, upon request, the apparatus required for carrying out other EN tests (such as the EN314-1 for plywood for example) or tests in compliance with ASTM, NZS, JIS standards. Apparatus may also be supplied for some particular tests which, although they are not standard, are nevertheless required by some board manufacturers.

IBX800

The IBX800 version is available which is equipped with a device to measure density profile as well. The X-ray assembly consists essentially of an X-ray source and a receiver between which the sample is placed for the density profile analysis. The density profile sample-holder can hold several samples at the same time which are separated by spacers that come with the supply: the unit scans each sample automatically, hence facilitating the task of the operator.

The operator can programme and carry out the tests which need to be conducted to control the quality of the board produced with simple operations. The user interface combines top level graphics with the most modern software technology for filing data and the subsequent data search. All the data are stored in an SQL server database, from where they may be exported to other applications, like Excel for example, and/or printed (in graph form and/or as a numerical report). It is possible to connect the database up to the plant network to share all the test results. The software has features that will help the operator to carry out the tests, such as for example a photograph showing which tools to use for a particular test and a short video tutorial.

A QR code reader may be installed as an optional for the automatic identification of samples prepared by the IMAL SMC200, to save time and avoid human error.

IB800 can import data from the DPX400 and DPX400-LTE density profile meters.

LABLOCK

The IB800 LABLOCK option is also available to carry out withdrawal and head pull-through resistance of pallet nails and staples (EN 12777-2) and Resistance of pallet joints (EN 12777-3) on pallet blocks.

Equipment to carry out the principal tests required by the CHEP standards (Chep TS-WP-BLOCK tine compression, Chep TS-WP-BLOCK nail insertion, Chep TS-WP-BLOCK nail pull/retention, Chep TS-WP-BLOCK tensile strength) may also be supplied upon request.

TEST IN PROGRESS



TEST REPORT

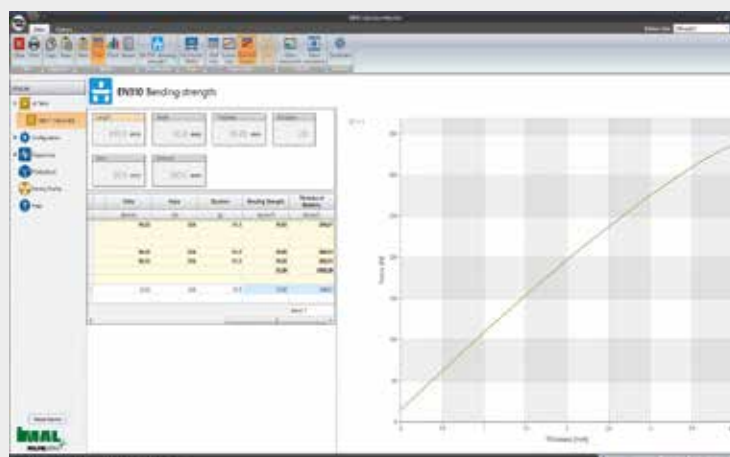

OPZIONE LABLOCK - LABLOCK OPTION



WATER BATH FOR SWELLING AND BOIL TESTS

SW200 & BT200



BEST IN CLASS FOR:

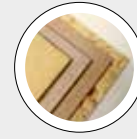

WOOD BASED PANELS:

PB/SPB

OSB/LSB/FOSB

MDF/HDF

The SW200 and BT200 appliances consist of a water bath which is used to carry out laboratory and immersion tests on samples of wood-based panels (particleboard, MDF, OSB) in accordance with EN European standard requirements (it may also be used in conjunction with other IMAL equipment) such as:

- Swelling and absorption (EN 317)
- Boil test (EN 1087-1)

The system has a control unit for regulating temperature as required by the EN standards. Up to 2 separate timers may be set on the touchscreen display (one per sample rack). Temperature is monitored from the trend view.

The equipment comes with racks for immersing the samples for the test that is to be carried out, the 2 racks for the EN317 swelling test have been designed to house the samples in full compliance with the standard requirements and the distances indicated. The number of samples which may be immersed will depend on sample thickness plus a minimum space between one sample and the next. The SW200 can hold up to 136 samples (depending on thickness). The 2 racks for the BT200 version for the EN1087-1 test can house the samples that have been glued to the relative supports, the bath can hold 24 samples.

Water temperature is set on the display in relation to the test which is to be carried out, and is regulated by a PID control; an immersion heater is fitted

inside the tank to regulate the water temperature at the required value. If the difference between water temperature set-point and the environmental temperature is less than 2°C, an optional immersion cooling circuit can be provided. Imal recommends a solution of this kind to keep the temperature where the machine is located at the recommended temperature and to ensure that the water remains "still" during the test as per the standard requirements.

The system is also equipped with a level control, safety temperature control and drain tap.

The SW200 and BT200 are an integral part of the IMAL Smartlab platform. A webserver is also included to monitor the state of the unit with remote connection from PC and mobile or tablet as well.

SW BLOCK 200 and BT BLOCK 200 versions are available for carrying out tests in accordance with UIC CODE 435-2 requirements

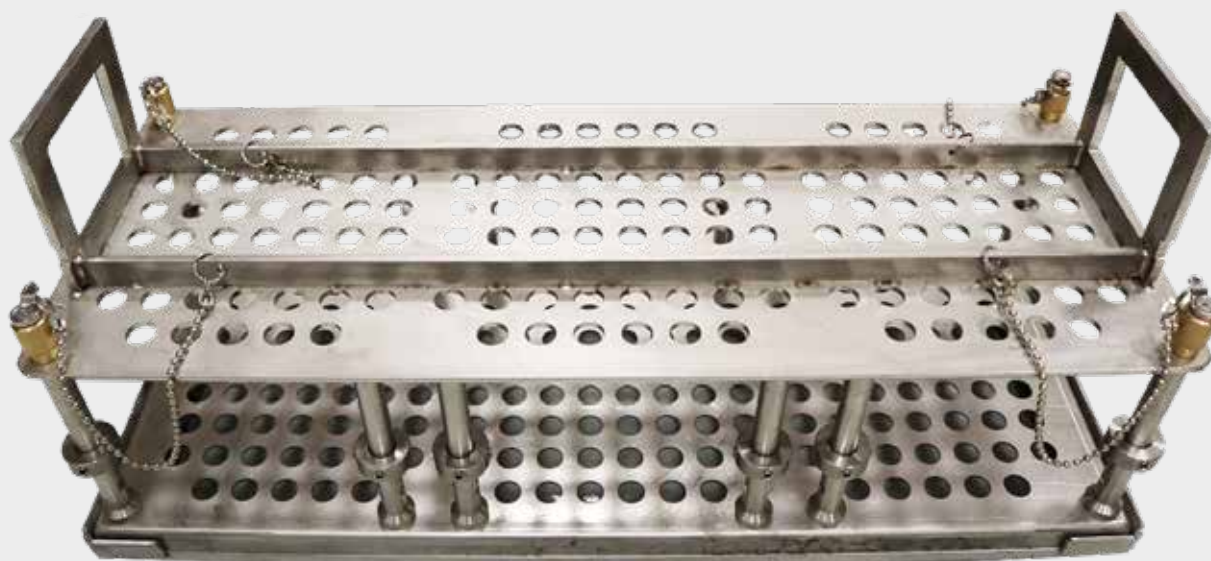

IN CONJUNCTION WITH IB800 BOARD PROPERTY TESTER

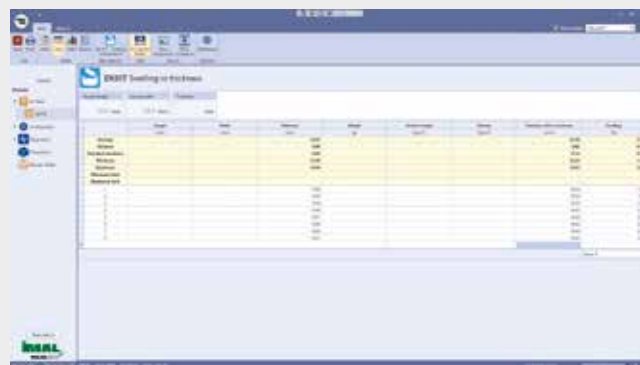
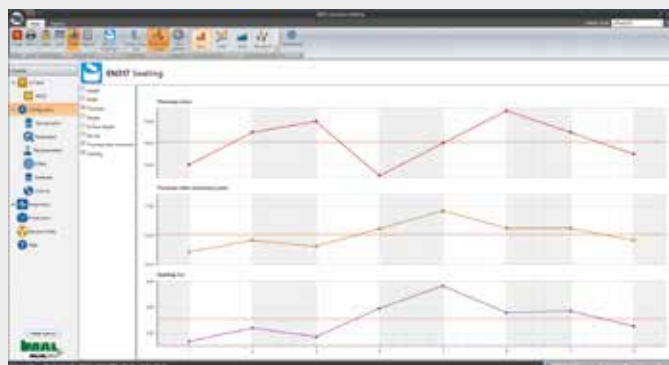

TECHNICAL DATA SW200 & BT200

OPERATING TEMPERATURE (EN 317)	20 °C
OPERATING TEMPERATURE (EN 1087-1)	100 °C
TEMPERATURE STABILITY	±1 °C
RESOLUTION	0.1 °C
NOMINAL SAMPLE SIZE	50 x 50 mm
WATER VOLUME	36 l
INSTALLED POWER	2.8 kW / 230 V
SAMPLES PER RACK SW200	24 ÷ 136 (in relation to thickness)
SAMPLES PER RACK BT200	12

TECHNICAL DATA SW200 BLOCK & BT200 BLOCK

OPERATING TEMPERATURE SW200 BLOCK / BT200 BLOCK	20 °C / 100 °C
TEMPERATURE STABILITY	±1 °C
RESOLUTION	0.1 °C
WATER VOLUME SW200 BLOCK / BT200 BLOCK	89 l / 55 l
INSTALLED POWER SW200 BLOCK / BT200 BLOCK	2.8 kW / 4.0 kW
NUMBER OF SAMPLES PER RACK SW200 BLOCK / BT200 BLOCK	10/6

X-RAY DENSITY PROFILE ANALYZER
DPX400 - DPX400-LTE

TO MEASURE BOARD THICKNESS AND TO PROVIDE THE DENSITY PROFILE



The DPX400 is a laboratory machine, used to supply the density profile of particleboard, OSB or MDF samples, measured along the thickness. The samples may be of varying thickness and may be measured individually or in groups so as to highlight any particular differences in material distribution at various points on the same board (e. g. different distribution on the two sides of the same board). The machine has been manufactured using top quality products and the most advanced, sophisticated technology. Its ergonomic and functional design provide handy access to all instruments in a work friendly environment.

MAIN FEATURES

- No contact with the sample
- High sensitivity and good measuring accuracy
- Greater intrinsic safety in relation to radioactive sources
- Two sample holders are supplied so that the operator may prepare a second set of samples while the first lot is being tested, to speed up the various operations
- Weighing scale with centesimal divisions
- Auto-gauging station to read width, length, thickness at the same time. A special programme designed to run with Windows, is used to set up the main parameters required to operate the equipment and to manage the measurement data collected. Thanks to this programme it is possible to view the density profile graph during the measurement procedure, to store it, print it, or to process some of the measurements. You can also select and display, for instance, some of the functions listed below:
- Average density
- Mirror image on the same density profile graph to highlight any differences which there could be between the two surfaces
- Maximum and minimum points
- Profile density as a percentage

BEST IN CLASS FOR:

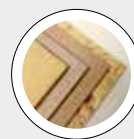

WOOD BASED PANELS:

PB/SPB

OSB/LSB/FOSB

MDF/HDF

(0-100%) or in kg/m³ • Comparison of several different density profiles on the same graph • Magnifying of any one area of the density profile. Each graph can be stored in the programme's database, which is SQL format, and by means of a simple dialogue box, it is possible to carry out searches on the data stored, using various search criteria (more than one of these may be used at a time) like:

- Production name
- Lot
- Thickness
- Date
- Time period

You can also configure zones called "average left", "average centre" and "average right" of the board on which you may calculate a partial density average, and which can be shown on the graph. The whole machine has been planned and designed with the operator's safety as the main objective; this is why an X-ray tube has been used instead of a radioactive source.

The intrinsic safety of employing an X-ray tube is due to two main factors:

- If there is no power supply going through to the X-ray tube, there is no emission

whatsoever • As tube emission is strictly linked to the control electronics, it is possible to obtain an amount of X-ray emission which gives excellent measuring resolution and accuracy but which, at the same time, is well below the intensity of radioactive sources normally used in industry, and therefore less dangerous. Furthermore, the material used to construct the container, and the internal layout of the various components are such that there is no risk of any emission outside the apparatus.

FUNCTIONING PRINCIPLE

The system proposed, based on the X-ray control theory, can analyse the density profile without any contact at all between material and measuring instrument: it comprises an X-ray source and a receiver, between which the density profile sample is placed. The sample is placed in a tray holder and is moved using high precision mechanics, which guarantee extremely small and accurate positioning and movements. Two sample holders are supplied so that the operator may prepare a second set of samples while the first lot is being tested, to speed up the various operations. The machine is of horizontal construction, which, as well as ensuring that it takes up as little space as possible, means that it is also easily integrated with other IMAL automatic and semi-automatic measuring equipment like the IB800 Board property tester. All the electronics required to govern movement and operation of the measuring unit (X-ray tube and relative receiver), are housed in one solid and compact assembly. The ideal emission intensity for the material being tested is obtained by varying the current and/or voltage to the X-ray tube. Rapid response and precision are the two main features of the receiver employed. The combination of these two features makes it possible, for the first time ever, to reach incredible speeds, whilst maintaining at the same time, exceptional precision as well as excellent measuring repeatability.

TECHNICAL DATA	
SIZE OF SAMPLE HOLDER	350 mm
SAMPLE THICKNESS	1+ 100 mm
MEASURING TECHNOLOGY ADOPTED	Collimated X-ray sources 28kV -1 mA
SCANNING SPEED	0.01 ÷ 0.5 mm/s
RESOLUTION	0.01 ÷ 0.05 mm
REPEATABILITY	0.1%
PRECISION	±0.1%
DATA PROCESSING STANDARDS	DIN, EN, ASTM, ANSI

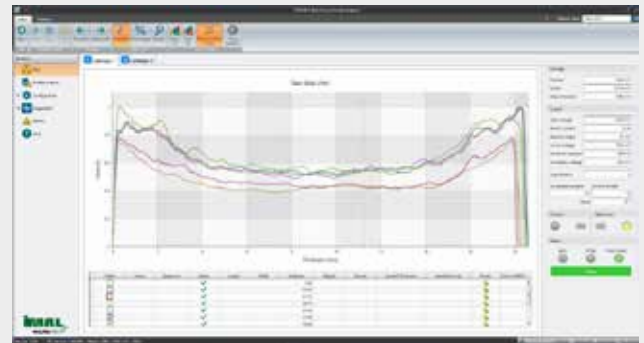

A smaller version is also available, the DPX400-LTE. The main difference to the standard version is that the dimensions in this case are measured by a digital calliper connected directly to the PC via USB and the sample holder is smaller, 200 mm, and not interchangeable. The two devices are identical in terms of X-ray analysis.



LAB FORMALDEHYDE TESTER

GA300

The GA300 apparatus for the gas analysis test permits a rapid calculation of the amount of formaldehyde released by wood-based panels. Testing is conducted to meet EN ISO 12460-3 standard requirements. The sample, which has been suitably prepared for testing, is placed inside an hermetically sealed chamber at a controlled temperature, pressure and air flow. The formaldehyde released by the sample inside the chamber collects in the controlled flow of hot air that travels through the chamber. The air containing the formaldehyde is passed through wash bottles at outfeed where the formaldehyde recombines with the water. The amount of formaldehyde contained in the water is measured using the photometric method. The result is given in milligrams of formaldehyde per square meter of board surface in one hour (mg/m²h).

The GA300 gas analyser rapidly provides details on the amount of formaldehyde released by the boards produced to enable timely corrections to the production parameters. Since a full test lasts approximately 4 hours, the results will be received around every 2 hours if a two chamber lab tester is used, (with respect to the sample taken during the previous 4 hours). Whereas, in the case of the four chamber tester, the results are received every hour.

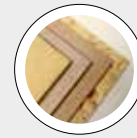
BEST IN CLASS FOR:**WOOD BASED PANELS:**

PB/SPB

OSB/LSB/FOSB

MDF/HDF

MAIN FEATURES

- Possibility of controlling 2 test chambers with one device (may be expanded to 4 chambers)
- Each chamber is able to control temperature and air flow regulation independently
- Test data may be printed and recorded after the analysis
- The gas collection times and temperature regulation may be configured should any changes be introduced to the standard, or for experimenting purposes
- As well as processing the data for each analysis, the central processor is able to supply the calibration value of the spectrophotometer.



TECHNICAL DATA

DIMENSIONS OF TESTING CHAMBER	96 x 555 mm
DIMENSIONS OF SAMPLE	50 x 400 mm
HUMIDITY OF AIR	2 ± 1% r.h.
OPERATING TEMPERATURE	60 °C ± 0.5
AIR PRESSURE	Mains pressure
OPERATING OVERPRESSURE	1000 ÷ 1200 Pa
AIR FLOW IN CHAMBER	60 ± 3 l/h
PRODUCTION SAMPLING FREQUENCY	2 test chambers: approx. every two hours 4 test chambers: approx. every hour
INSTALLED POWER	1.3 kW or 2.5 kW

OPTICAL LAB FIBRE SCREEN

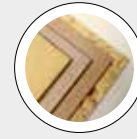
FIBERCAM100 - SCREENCAM100TO MEASURE THE PERCENTAGE OF THE VARIOUS GRANULOMETRIES OF
THE FIBERS AND PARTICLES**BEST IN CLASS FOR:**

WOOD BASED PANELS:

PB/SPB

MDF/HDF

The application of optical technology permits an accurate measurement of the dimensions of the fibers (FIBERCAM100) and particles (SCREENCAM100), without ruining the materia in any way (as happens with water systems), with elevated repeatability and rapid response times. The analyzing software, in conjunction with the numerous images taken, calculates the actual length (extension) and width of the fibers/particles even in cases where they are laid one over the other. Denser \pm umps, on the other hand, are not analyzed.

The result of each test is stored in the local database and may be consulted over the company network. In addition, the test results may be printed with the figures and the graph showing the granulometry distribution.

The impartial verification of test repeatability and/or comparison with previous tests, is made by placing one graph over the other by means of a simple set of menu choices.

Automatic cleaning system with connection to external vacuum cleaner.

Are available also the online versions for measuring and processing the principal properties of the fibres/particles directly in the process, hence the measurements are virtually taken real time, it takes just about 3-5 seconds to reach the scanning unit.

MAIN FEATURES

- Accurate measurement of the true dimensions
- Elevated repeatability
- Test performed rapidly
- Measurement easily conducted
- Simulation of any number of sieves
- Simple to use
- Suitable for application on line (optional).



IMAL Srl - Via R. Carriera, 63 - 41126 San Damaso (MO) - Italy
Ph: +39 059 465500 - Fax: +39 059 468410 - info@imal.com



TECHNICAL DATA

MEASURING RANGE FIBERCAM100	0.05 ÷ 30 mm
MEASURING RANGE SCREENCAM100	Two ranges available [0.10 ± 35mm][0.25 – 70mm]
NO. OF SCREENS	up to 15 virtual sieves may be programmed
TEST TIME	< 2 min
REPEATABILITY	error < 1%
MAX SCANS	up to 800,000 image/min
CLEANED AUTOMATICALLY AFTER EACH CYCLE	yes

INFRASONIC LABORATORY SIFTER

VU200

TO ASSESS THE PERCENTAGE OF THE VARIOUS GRANULOMETRIES PRESENT IN THE MATERIAL



The has been designed to screen out products like sawdust, chips, and wood fibre, in relation to particle size. By applying an acoustic pressure of adjustable frequency and intensity, the material is dry-sieved and collected in calibrated screens which are positioned in decreasing order. By weighing each sieve, the operator may calculate the percentage of the single granulometries, and obtain numerical information on the composition of the material used.

MAIN FEATURES

- Used for both fibre and wood chips
- Excellent screening precision in a very short time
- Acoustic vibration to prevent the material from accumulating
- Single oscillating air column to move even the smallest particles through the sieves
- No screen wear or particle friction
- See-through sieves to inspect the screening process
- Simple to use
- It can house up to 9 sieves with a diameter of 150 mm including the bottom and the lid.

TECHNICAL DATA

POWER SUPPLY	110/230 V - 50/60 Hz
OPERATING TEMPERATURE RANGE	+5 ÷ 45 °C
MAX. HUMIDITY	Any
WEIGHT	35 kg
DIMENSIONS	450 x 850 x 460 mm
SIEVE DIAMETER	150 mm (internal 129 mm)

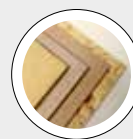
BEST IN CLASS FOR:**WOOD BASED PANELS:**

PB/SPB

OSB/LSB/FOSB

MDF/HDF

ADVANTAGES

- Accurate quality control of the material used in the productive process
- Improvement in the quality of the boards produced
- Less material wasted in the production process.

BEST IN CLASS FOR:



WOOD BASED PANELS:

PB/SPB

OSB/LSB/FOSB

MDF/HDF

VIBRATING SIFTER

VM100

TO ASSESS THE PERCENTAGE OF THE VARIOUS GRANULOMETRIES PRESENT IN THE MATERIAL



Electro-magnetic impulse operated Sifter, controlled by a separate micro-processor with the following functions:

- Sifting time can be set from 0 to 20 minutes
- Variable vibrating intensity
- Continuous or adjustable intermittent sifting mode.

The vibrating action combines three different types of movement (vertical-lateral-rotational), making this vibrating sifter extremely efficient and reliable. It can house up to twelve sieves with a diameter of 200 mm inclusive of the bottom and lid, or ten 300 mm diameter sieves with bottom and lid.

TECHNICAL DATA

ABSORBED POWER	450 W
ELECTRICAL POWER SUPPLY (SINGLE PHASE)	110/230 V 50/60 hz
DIMENSIONS (Ø x h)	450 x 1200 mm
SIEVE DIAMETERS AVAILABLE	200 - 300 mm
MAX NUMBER OF SIEVES WHICH MAY BE FITTED	11
VIBRATIONS PER MINUTE	max 3000 N°/min



IMAL Srl - Via R. Carriera, 63 - 41126 San Damaso (MO) - Italy
Ph: +39 059 465500 - Fax: +39 059 468410 - info@imal.com

OSCILLATING SCREENS
LS300/400



BEST IN CLASS FOR:

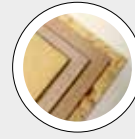

WOOD BASED PANELS:

PB/SPB

OSB/LSB/FOSB

MDF/HDF

The laboratory screens are designed for an accurate simulation of the industrial process, obtaining results which are comparable to the process itself.

The LS consists of a base which supports a central shaft equipped with balancing counterweights and motor.

The screening box consists of a modular set of sieves mounted on a plate fixed to an eccentric shaft, which is supported and driven by the central shaft. Both shafts (the central driving shaft and the upper eccentric shaft) are assembled on special lubricated bearings which ensure a precise and smooth eccentric oscillating movement.

SIEVES FOR LS300/400							
ITEM	SIZE mm	INCH /MESH	DIAMETER mm	WIDTH mm	DEPTH mm	HEIGHT mm	
1	35	1 3/8"	300	900	550	1300	
2	25	1"					
3	20	NONE					
4	16	5/8"					
5	10	NONE					
6	8	5/16"					
7	6.14	NONE					
8	5	NONE					
9	4.5	NONE					
10	4	N. 5					
11	3	NONE					
12	2	N. 10					
13	1.5	NONE					
14	1.4	N. 14					
15	1.34	NONE					
16	1.27	NONE					
17	1	N. 18					
18	0.8	NONE					
19	0.71	N. 25					
20	0.6	N. 30					
21	0.5	N. 35					
22	0.4	NONE					
23	0.35	N. 45					
24	0.307	N. 50					
25	0.25	N. 60					
26	0.237	NONE					
27	0.14	N. 100					
28	0.063	N. 230					
ITEM	SIZE mm	INCH / MESH	DIAMETER mm	WIDTH mm	DEPTH mm	HEIGHT mm	
1	30	-	400	900	550	1300	
2	19.8	-					
3	12	-					
4	10.5	-					
5	10	-					
6	7.96	-					
7	6	-					
8	5.06	-					
9	4	-					
10	2	-					
11	1	-					
12	0.237	-					

TECHNICAL DATA

Movement	Eccentric-oscillatory
Eccentricity	25 mm
Operating time	0 ÷ 8 min
Sieve diameter	300 mm or 400 mm
Sieve height	70 mm
Stainless steel sieves	Up to n.8
Installed power	0.37 kW
Voltage	110/220 V 50/60 hz

GLUE MIX GEL TIME CONTROL

GEL TIMER

TO ENSURE PERFECT TEST REPEATABILITY AND GEL TIME ACCURACY



The Geltimer has been designed to measure the gel time of the resin delivered by the supplier and the gel time of the glue mix applied in the blender and the blow line.

It permits the glue comparison between several different production plants to assess quality repeatability of the various resins supplied.

The device produces highly accurate measurements: the electronic system measures mixer motor torque and hence the absorption power. The initial torque value when the mixer is immersed in the resin and started, is zero (offset). A difference is set, beyond which the resin is considered to have hardened.

MAIN FEATURES

- Accurate measurements • Elevated repeatability • Test conducted rapidly
- Easy to use • Test results may be saved (up to 200) • Up to 200 sensitivity settings possible.

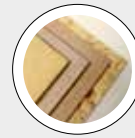
BEST IN CLASS FOR:

WOOD BASED PANELS:

PB/SPB

OSB/LSB/FOSB

MDF/HDF



TECHNICAL DATA

Motor power	6 W
Power supply	230 V 50/60 Hz
Environmental operating temperature	+10 ÷ 40 °C
Degree of humidity	< 85% without condensation
Other environmental conditions	Enclosed environment/room, non explosive atmosphere

LABORATORY FORMER

LABFORMER100

TO FORM AND PRODUCE SAMPLE PANELS FOR TESTING PURPOSES



LABFORMER100 has been designed to produce a 500mm x 500mm MDF or particleboard panel with density evenly distributed over the surface, in a simple and rapid manner (other sizes on request).

The material is loaded into the former on a tray, which may be filled beforehand. Once the tray is loaded, the material is conveyed by a belt, the speed of which may be set via the software. A set of speed-controlled, height adjustable comb rolls form the mat in a homogenous manner. The speed at which the bottom tray moves may also be adjusted to achieve an optimal longitudinal distribution of the material. Lastly, a cylinder pre-presses the newly formed mat before it is extracted to be hot pressed. The software has a self-learning function making it possible to calculate, at the start of each new test, the number of longitudinal cycles which need to be run to ensure that the mat is composed of complete layers and that it is perfectly flat.

At the end of the mat forming cycle, the mat can be pre-pressed by the pneumatic cylinder located in the tray discharge area. The portable tray is used to remove the mat and place it in the hot press to produce the board for testing purposes. The front panel is equipped with a user-friendly touchscreen for all the various parameter settings. The data for the mat which is to be produced is set from the screen and the various recipes may be saved in the database for easy retrieval in future.

BEST IN CLASS FOR:

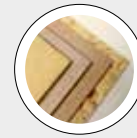

WOOD BASED PANELS:

PB/SPB

MDF/HDF

MAIN FEATURES

- Adjustable forming belt speed
- Adjustable roll height
- User friendly touch screen
- Self learning software
- Internal database
- Pre-press.

USER FRIENDLY SOFTWARE INTERFACE



TECHNICAL DATA

MAT DIMENSIONS	500 mm x 500 mm standard (600 x 600 or 500 x 800 also available, other sizes on request)
MAXIMUM FINISHED BOARD THICKNESS	MDF 3 - 40 mm, PB 8 - 50 m
MAXIMUM DIMENSIONS	W: 1200 mm, L: 4300 mm, H: 1800 mm
APPROXIMATE WEIGHT	1600 kg
BUILT-IN ELECTRICAL PANEL	Yes
7" COLOUR TOUCHSCREEN DISPLAY	

LABORATORY PRESS

PL100

TO PRESS BOARD FOR BOARDS FOR TESTING PURPOSES

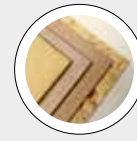
**BEST IN CLASS FOR:**

WOOD BASED PANELS:

PB/SPB

OSB/LSB/FOSB

MDF/HDF

The laboratory press is able to produce sample boards for testing purposes, with adjustable specific pressure and adjustable temperature for binder curing. The PL100 Laboratory Press is produced in a standard 600 x 600 mm version but other sizes may be evaluated upon request.

The laboratory press has its own electronic control which reads the signal coming from a level transducer and the pressure inside the cylinder.

The data regarding the cycle required is stored in its memory. The system controls the various phases of the cycle following a logic sequence, and the switching over from one phase to the next occurs as soon as a specific condition is fulfilled. The parameters available to the operator are thickness, time, pressure and internal temperature of the board during the press cycle.

The memory is ample enough to store a large number of cycles (the number is limited by the computer's hard disk storage capacity), and the parameters relating to each cycle are stored as well.

The system directly controls the hydraulic valves to obtain the desired cycle.

The software has been developed on two bases: a computer to set, store and display the data, for which clear and intuitive graphics are used, and a micro-processor for the actual control of the process, which has been created with the aid of sturdy and reliable HW, suitably designed for the purpose.

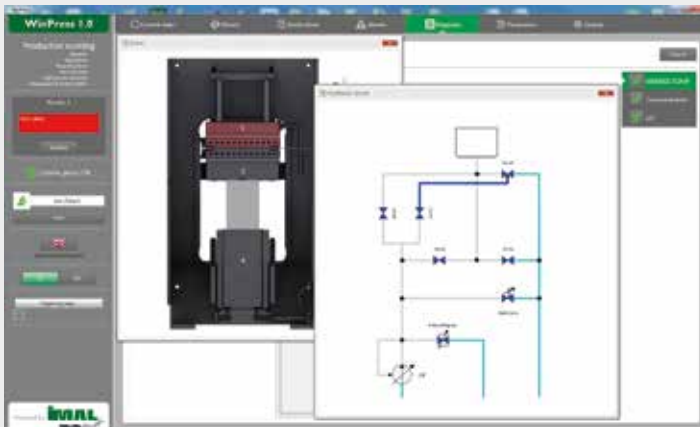

TECHNICAL DATA

HOT PLATEN SIZE	600 x 600 mm
AVAILABLE WITH DIFFERENT PLATEN SIZE	YES
OPERATING PRESSURE	max 250 bar (3620 PSI)
HOT PLATEN TEMPERATURE	250 °C (480 °F)
INSTALLED POWER	26 kW
SPECIFIC PRESSURE 600 X 600 AT 250 BAR	540 N/cm ² (782 lbf/in ²)
CYLINDER DIAMETER	320 mm (12 5/8")
PRESS APERTURE/CYLINDER STROKE	400 mm (15 3/4")
DIFFERENT PRESSING CYCLES SETTABLE	YES
POWER AND PHASE (AS PER SITE INSTALLATION REQUIREMENTS)	from 400 V / 50 Hz
INCORPORATED HYDRAULIC CONTROL UNIT	YES
TOUCH SCREEN COMPUTER/MONITOR	YES
INCORPORATED ELECTRICAL CABINET	YES

LABORATORY GLUE BLENDER

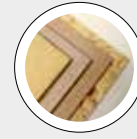
LGB**BEST IN CLASS FOR:**

WOOD BASED PANELS:

PB/SPB

OSB/LSB/FOSB

MDF/HDF

The glue blender, installed on a metal supporting structure, consists of a suitable sized drum, a top door for manually loading the material, and a bottom door through which the material is discharged. The mixing tools inside the drum are mounted on a shaft which is operated by a gear motor. Pneumatic nozzles spray the glue mixture onto the material.

A small graduated tank containing the glue mixture, is situated at the top of the assembly.

The glue mixture flows at a variable rate into the blender by means of a manual valve. The machine comes complete with an electric control panel.

The mixing time of the shaft may be set using the timer.

LGB100

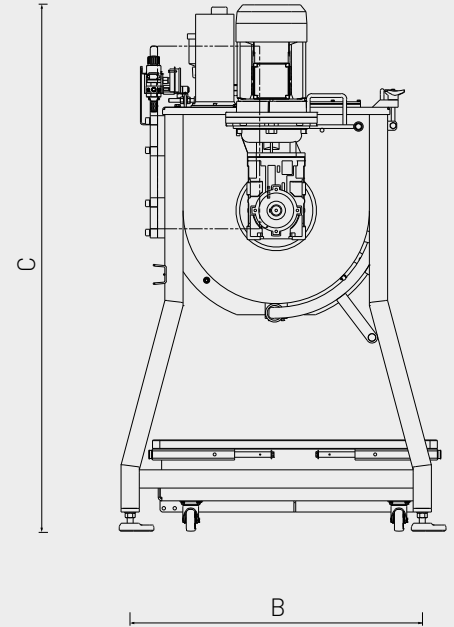
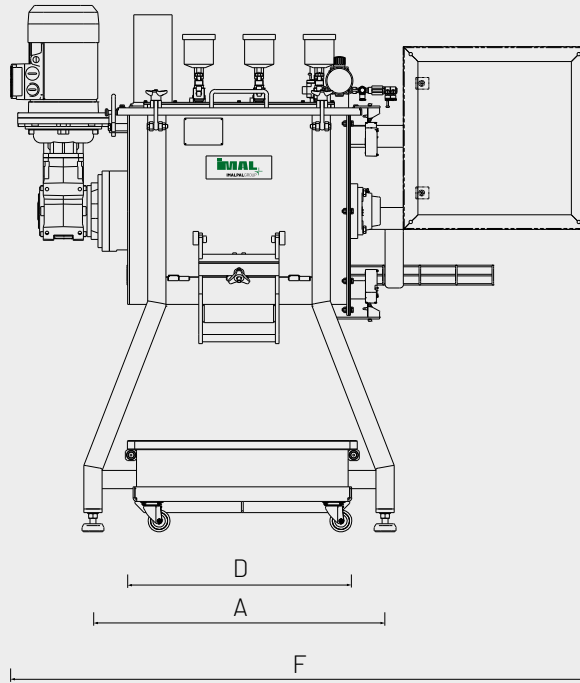

LGB300

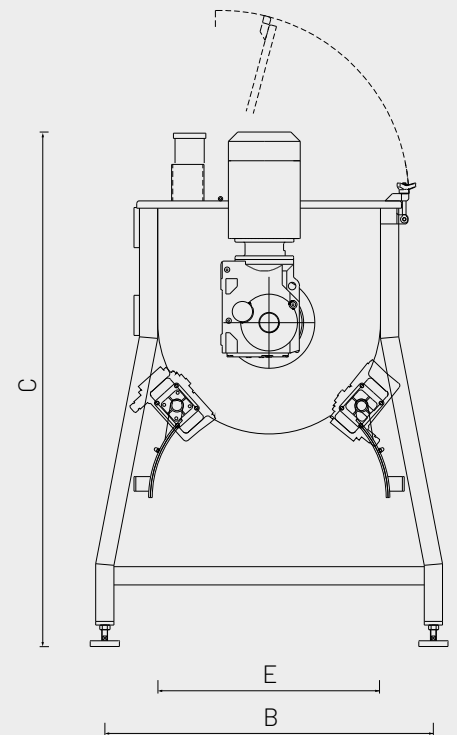
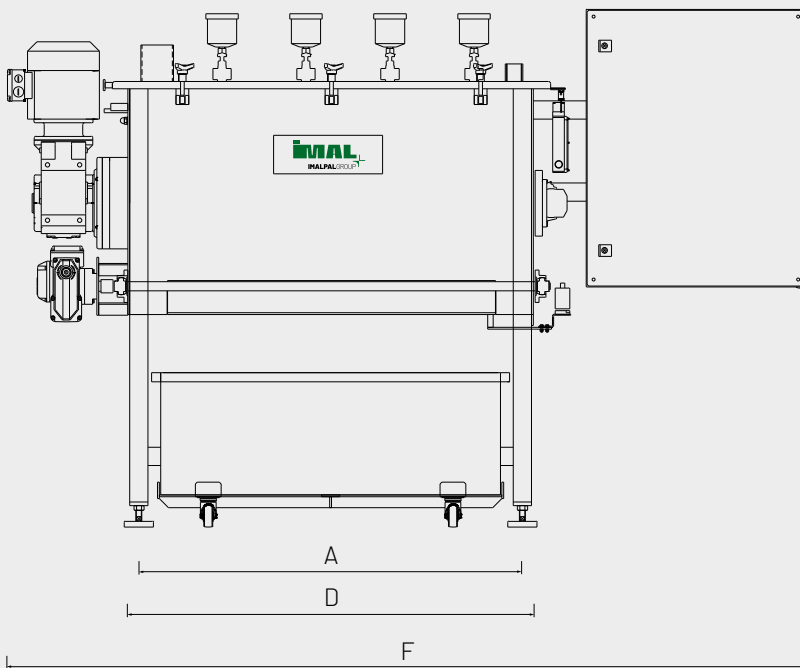

MODEL	MAX. FLOW dm ³	MAX. POWER kW	OVERALL DIMENSIONS mm					
			A	B	C	D	E	F
LGB100	100	3	800	800	1450	605	510	1570
LGB300	300	1.1	1050	900	1450	1100	650	2185

LABORATORY MOISTURE METER

UM3000

TO ASSESS MOISTURE CONTENT, BOARD DENSITY AND PERCENTAGE OF SCREENING RESIDUE



The UM3000 has been designed to measure the amount of moisture contained in the material. The material is dried by the heat coming from an infrared lamp. The method used is unaffected by any side effects which may be caused by colour, density, chemical properties or absorption which, with other methods, could produce unreliable results. It is equipped with a colour touchscreen for entering the data for the sample to be tested simply and rapidly and where the results are displayed graphically and numerically in a user-friendly manner and stored in the internal database. The unit comes with a printer for printing the report. The results may also be transmitted via Ethernet to the facility's project data management or shared over the IMAL Smartlab platform. A web server is also included to monitor the state of the device with remote connection not only via PC but also via smartphone or tablet.

MAIN FEATURES

- Internal temperature control
- Integrated thermal printer to print data and graphs directly
- Rapidly calibrated (directly from keyboard)
- User friendly interface
- Calibration certification using primary reference samples
- May be used with all kinds of powdery and/or granular material.

ADVANTAGES

- Elevated measuring precision
- Tests carried out rapidly
- Measuring repeatability
- No maintenance required.

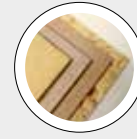
BEST IN CLASS FOR:**WOOD BASED PANELS:**

PB/SPB

OSB/LSB/FOSB

MDF/HDF

AUTOMATIC P CONTROL

This function enables you to view and print the moisture percentage in relation to the dry weight (ATRO) as well as to the initial weight (Total), showing the month, day and time of the test (hour and minutes). The sample is weighed before and after the drying process. The measuring procedure ends when the variation in weight over a time unit (programmable in seconds) falls below or is equal to the P which has been set (programmable in 1/100 g).

• \emptyset Dry material: $((W_i - W_f) / W_f) * 100$ (moisture to dry weight) • \emptyset Wet material: $((W_i - W_f) / W_i) * 100$ (moisture to total weight) where W_i =initial weight; W_f =end weight.

MANUAL TIMER CONTROL

The operator sets the time for the measuring cycle in minutes, and at the end of the cycle, the final weight and moisture content are displayed and stored and/or printed.

WEIGHT DISTRIBUTION – WEIGHING SCALE

This function enables you to print the weight distribution graph. The samples are obtained by cutting a strip of board into equal parts and weighing each part. Once the sample has been measured, a graph is printed showing the weight distribution and the deviation if any, from the average value.

SCREENING RESIDUE PERCENTAGES SCALE

With this function it is possible to calculate and print the relative percentages of the material which has settled in the various sieves at the end of the screening cycle.

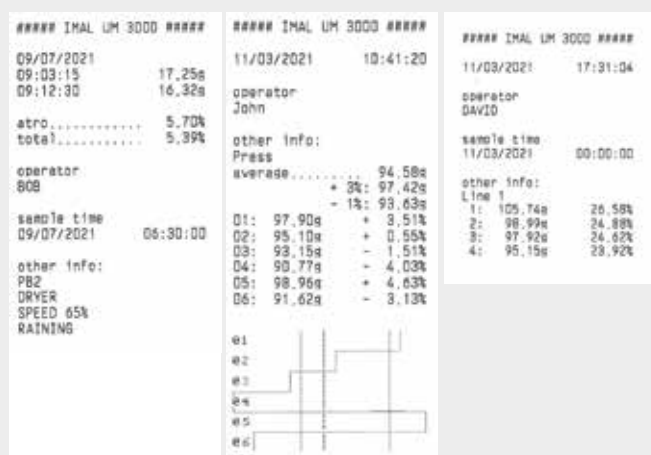

SOFTWARE INTERFACE

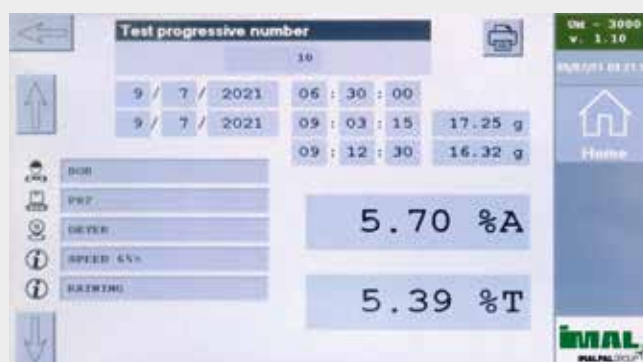

TECHNICAL DATA	
MAX CAPACITY	1000 g
READING DIVISION	0.01 g
MOISTURE RESOLUTION	0.01%
ENVIRONMENTAL TEMPERATURE	+5 ÷ 40 °C

LABORATORY MOISTURE METER

UM2000-LTE

TO DETERMINE THE MOISTURE CONTENT OF ANY KIND
OF POWDER AND/OR GRANULAR MATERIAL

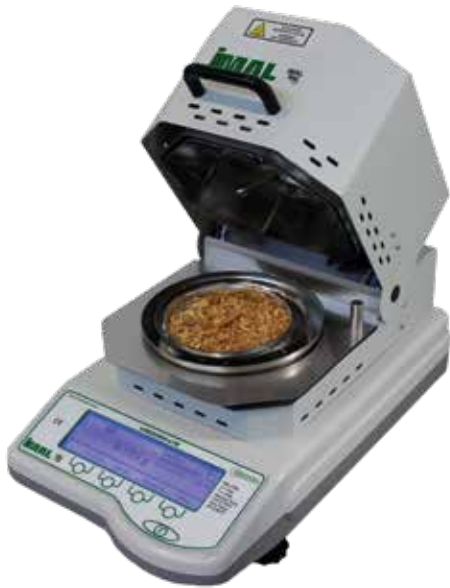

The UM2000-LTE has been designed to determine moisture content in a very simple and reliable manner. The material is dried by a round halogen quartz lamp which applies a constant heat to the sample, at one or more temperatures that have been programmed accordingly by the operator.

The method is not influenced by the effects produced by colour, density, chemical properties or absorption which can render the measurements obtained by other methods unreliable. A sample of suitable weight is placed on the scale pan inside the drying chamber.

The test parameters are programmed from the keyboard beforehand by the operator and the test starts when the relative key is pressed or when the lid is closed.

The unit has a large LED display to facilitate the reading of the data and a luminous bar to display the weight of the sample in proportion to the full scale and to monitor the weighing process.

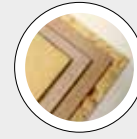
BEST IN CLASS FOR:**WOOD BASED PANELS:**

PB/SPB

OSB/LSB/FOSB

MDF/HDF

MAIN FEATURES

- RS-232 bi-directional data interface and USB for handling and storing test results and setup parameters
- Various drying modes which are easy to programme and retrieve
- Internal temperature control over a range of 50 ÷ 160 °C
- Specially designed, user-friendly software
- Calibration certified with primary gauging samples.

ADVANTAGES

- Elevated measuring accuracy
- Test conducted rapidly
- Good measuring repeatability
- No maintenance required.

```

MOISTURE TEST
FILE NAME:      Surface
DATE:           24/02/2011
TIME:           18:33:25
SER NO:         00AE809387
TEST NO:        1
USER NO:        000000
Result:         %ATRO MOISTURE
Heating:        Single
                110 C
Interval:       10 Sec
Stop:           STABLE
                0.002 g
                60 Sec
Start:          MANUAL
INIT MASS:     4.823 g

MODE  TEMP  TIME  RESULT
Single 41C  00:10  0.17 %AM
Single 62C  00:20  0.90 %AM
Single 82C  00:30  2.03 %AM
Single 99C  00:40  3.32 %AM
Single 111C 00:50  4.42 %AM
Single 111C 01:00  5.10 %AM
Single 111C 01:10  5.47 %AM
Single 110C 01:20  5.77 %AM
Single 110C 01:30  5.98 %AM
Single 111C 01:40  6.16 %AM
Single 110C 01:50  6.30 %AM
Single 110C 02:00  6.44 %AM
Single 110C 02:10  6.56 %AM
Single 111C 02:20  6.66 %AM
Single 110C 02:30  6.73 %AM
Single 111C 02:40  6.80 %AM
Single 111C 02:50  6.89 %AM
Single 111C 03:00  6.94 %AM
Single 111C 03:10  6.99 %AM
Single 111C 03:20  7.04 %AM
Single 111C 03:30  7.06 %AM
Single 111C 03:40  7.08 %AM
Single 111C 03:50  7.11 %AM
Single 111C 04:00  7.13 %AM
Single 111C 04:10  7.15 %AM
Single 111C 04:20  7.18 %AM
Single 111C 04:30  7.20 %AM
Single 111C 04:40  7.20 %AM
Single 111C 04:50  7.20 %AM
Single 111C 05:00  7.23 %AM
Single 111C 05:10  7.23 %AM
Single 111C 05:20  7.25 %AM
Single 111C 05:30  7.25 %AM
Single 111C 05:40  7.27 %AM
Single 111C 05:50  7.27 %AM
Single 111C 06:00  7.27 %AM
***** AUTO STOP *****
LAST TEMP:      111 C
FINAL MASS:     4.496 g
TEST TIME:      06:00
MASS LOST:      0.327 g
RESULT:         7.27 %AM
    
```

WORKING PRINCIPLE

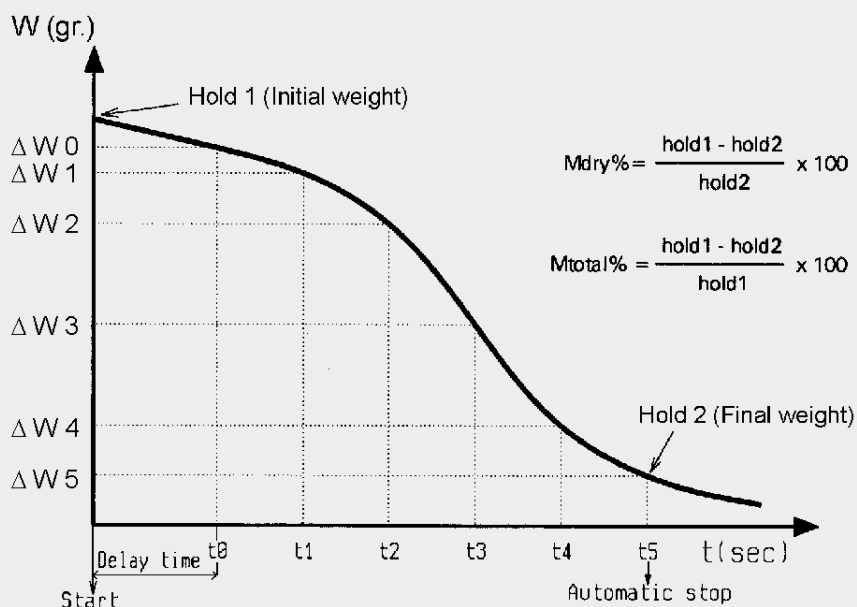

TECHNICAL DATA

MAX capacity	50 g
Reading division (d)	1 mg / 0.01%
Moisture resolution	0.01%
Weighing repeatability	2 mg s.d.
Moisture repeatability	10 g 0.05% sample
Min recommended weight	2 g
Environmental temperature	0 ÷ +40 °C

AUTOMATIC CALCULATION PROGRAMMES

% of moisture in relation to the initial weight	Initial mass - dry mass / initial mass
% of solids	Dry mass / initial mass
ATRO % M	Initial mass - dry mass / dry mass
ATRO % S	Percentage of solids/dry base

CRITERIA FOR STOPPING THE DEVICE AUTOMATICALLY

Stop when three consecutive results are identical	Interval between one readout and the next programmable from 5 to 99 sec.
Stop when three consecutive results are identical or at end of maximum time programmed	Time and readout intervals programmable from between 5 and 99 sec.

HEATING CRITERIA

Traditional drying	Gradual heating to the final temperature within the period of time set by the operator.
Step drying method	Heating to temperature 1 for x minutes, then to temperature 2 for x minutes, then to temperature 3 for x minutes (3 stages).
Quick pre-heat	The temperature rises to 30% beyond the temperature set and then falls to the temperature required. This procedure is useful for expediting test times for certain kinds of products.

MOISTURE METER

UC950

TO MEASURE MOISTURE CONTENT OF WOOD CHIPS AND SAWDUST ON
ARRIVAL AT THE PLANT



The system has been designed to provide a rapid measurement of the moisture content present in wood chips and sawdust manually, at the entrance to the production facility, so that the actual cost of the raw material may be determined on a dry basis.

The material is collected by the operator from the truck transporting the chips or sawdust at the entrance to the production facility and then placed in the chute (35 - 50 litres). The system levels the material and immediately measures moisture content within a range of 10% - 150% on a dry basis and the moisture content over the total within a range of 10%- 60%. The moisture content measured is then displayed on the screen.

Microwave technology is applied to conduct the measurement which is extremely rapid and accurate since the measurement is taken over an area of approximately 300 mm. The result may be printed utilizing the built-in printer. The printout may then be stapled to the delivery note to determine the actual cost of the raw material on a dry basis.

Once the measurement has been conducted the material is emptied from the chute manually, so that the system is ready to conduct the next test.

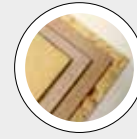
BEST IN CLASS FOR:

WOOD BASED PANELS:
PB/SPB
MDF/HDF

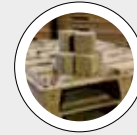

PRESSED WOOD PACKAGING:
PALLET BLOCKS



PELLETS & ENERGY:
GREEN FUELS AND BIOMASS



TECHNICAL DATA

MOISTURE RANGE	10% - 60% referred to the total (TOTAL) 10% - 150% referred to a dry basis (ATRO)
OPERATING TEMPERATURE RANGE	-5 ÷ +50 °C
MEASURING TIME FROM WHEN THE SAMPLE IS INSERTED	20 sec max
REMOTE OUTPUTS	via analogue 4 - 20 mA output or serial port
VOLTAGE	115 - 230 VAC
PRINTER	yes

SANDING, MARKING & CUTTING MACHINE FOR LABORATORY TEST SAMPLES

SMC200

SAND, MARK & CUT

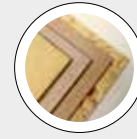
**BEST IN CLASS FOR:**

WOOD BASED PANELS:

PB/SPB

OSB/LSB/FOSB

MDF/HDF

PLYWOOD

The SMC200 is a fully automatic system for preparing laboratory samples for testing purposes. Once the strip taken from the production line has been inserted into the process, it is cut into samples on the basis of the cutting pattern programmed. If contemplated in the cutting pattern for standard compliancy purposes, the SMC200 can also sand the top and bottom of the sample with extreme precision. The rejects are separated out from the good samples at the end of the cycle and these are marked with a QR code for performing EN tests with other IMAL systems like the IB800 and an alpha-numeric code for rapid identification.

MAIN FEATURES

- The SMC200 is able to handle the cutting and sanding of the samples autonomously, starting from the "laboratory cut" made by the continuous saw; this gives the operator time to concentrate on other tasks such as running the tests themselves.
- To achieve a quality cut and sanding of the samples with repeatability, the SMC200 does not require operator intervention for the preparation of the samples hence ensuring a constant sample quality.
- For an optimal distribution of the samples over the panel.
- To manage the number and size of the samples which are to be cut.
- To keep track of the samples that have been cut.

The SMC200 cuts and sands the samples with 0.1 mm precision, thus ensuring that the samples are produced with straight edges and parallel surfaces.

- To run an elevated number of tests daily with the assistance of just one operator
- To cut and sand the samples without putting operator safety at risk, the SMC200 does not require operator intervention hence minimizing exposure to unnecessary risks.

The SMC200 cuts and sands the samples with 0.1 mm precision, thus ensuring that the samples are produced with straight edges and parallel surfaces.



The operator uses the alphanumeric code to separate and order the samples allocated for the various tests. The Data Matrix code is used to identify the sample in the database and allows compatible equipment (e.g.: IB800) to access the position data that the SMC200 has stored.



CUTTING PATTERN VIEW



DEBUG VIEW



TECHNICAL DATA

POWER SUPPLY	400 V
POWER INSTALLED	23 kW
CUTTING RANGE WIDTH	Up to 630 mm
CUTTING RANGE LENGTH	Up to 4000 mm
CUTTING RANGE FINAL SAMPLE THICKNESS	25 ÷ 1350 mm
DATA PROCESSING	DIN, EN, ASTM, ANSI
AIR PRESSURE	6 bar
SUCTION	Option - 12.000 m ³ /h , 25 m/sec.
DIMENSIONS	6.600 x 2.200 x 2.150 mm

LABROUGHNESS



BEST IN CLASS FOR:

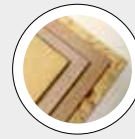

WOOD BASED PANELS:

PB/SPB

MDF/HDF

The LABROUGHNESS Roughness Optic Control has been designed to select and grade samples of wood-based panels in relation to their surface roughness; the device is able to supply an analysis of the surface profile of the sample. The sample grading is determined by the analysis of the parameters obtained, e.g. Ra, Ry, Rz... The device is equipped with a camera that takes high resolution photographs of the surface of the sample that is being analysed.

It has a built-in touch panel for carrying out all the operations required. It may be connected via Ethernet to a PC for carrying out a more detailed analysis utilizing the dedicated WinRough software supplied with the unit.

MAIN FEATURES:

- Non-invasive measurement: unlike traditional contact methods, the system utilizes an optic laser triangulation technique to conduct the test
- Profile with micron resolution
- Possibility of conducting up to 3 scans on the sample analysed along different pre-established paths
- Rapid response
- High resolution image of the surface of the board
- User-friendly software for analysing and storing the data and images taken by the unit

ADVANTAGES:

- Samples graded on the basis of their surface finish, to select the most suitable ones for the subsequent work processes such as lacquering and lamination
- Improved board quality
- Fewer rejects

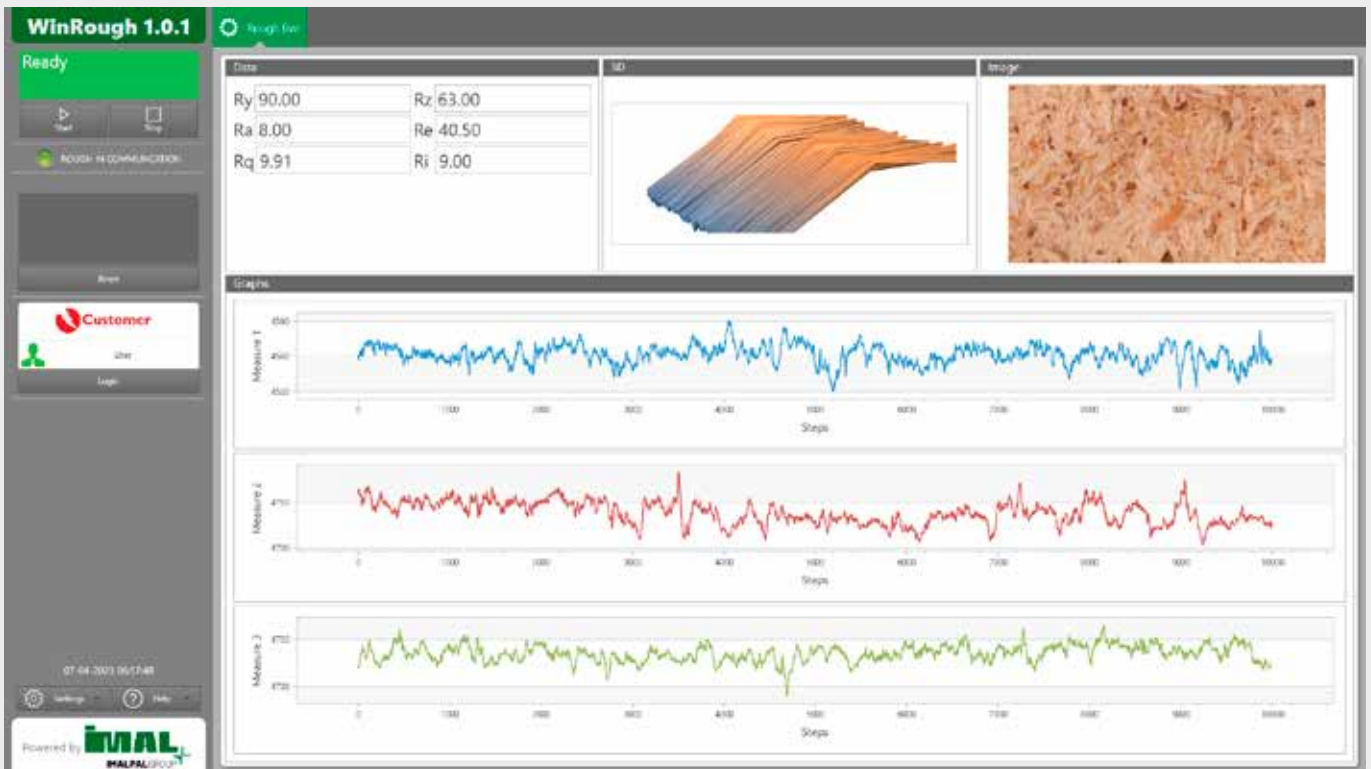

MAIN FEATURES

SAMPLE SIZE	100 mm x 100 mm
MAXIMUM SAMPLE THICKNESS	65 mm
LASER TRIANGULATION SENSOR RESOLUTION	1 μ m
CAMERA RESOLUTION	2 Mpixel/cm ²
POWER SUPPLY	220 Vac - 110Vac

