

DOSING BINS

**LIVE BOTTOM PITS**

FOR CHIPS, SAWDUST, SHAVINGS, WET &amp; DRY PARTICLES

**TECHNICAL FEATURES**

- Versatile storage-dosing live bottom pits: DB.6-9-12 with open-top for feeding with front loader – DBC.4 closed execution for metering of chips – DBD.4 special application for metering of Driers – DB1.1 & 2.2 for simultaneous metering of two downstream
- Destorage system based on live bed made up of modules of two or three dosing screws (parallel or opposed construction)
- Separate drive for each series of dosing screws
- Level controls.

**BENEFITS**

Storage-dosing of fractioned materials, wet or dry, such as chips, sawdust, shavings, particles, etc.

- Accurate dosing of several downstream machines, e.g.: roll screens – cleaners or sifters for chips, sawdust and shavings – knife ring flakers – hammermills – driers – dry screens – dry mills
- No bridge formation
- No material demixing
- Wide range of extraction capacity: running the dosing screw modules separately, alternatively or all together – driving each motor with a frequency converter
- High dosing accuracy from progressive pitch screws
- High efficiency and reliability
- Low maintenance.

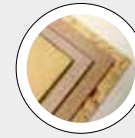
**BEST IN CLASS FOR:**

WOOD BASED PANELS:  
MDF/HDF  
PB/SPB  
INSULATION BOARDS

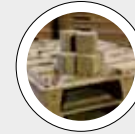

PRESSED WOOD PACKAGING:  
PALLET BLOCKS



PELLETS & ENERGY:  
WOOD PELLETS AND  
BLACK PELLETS  
LIME

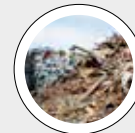

WOOD RECYCLING AND  
WASTE TREATMENT:  
WASTE

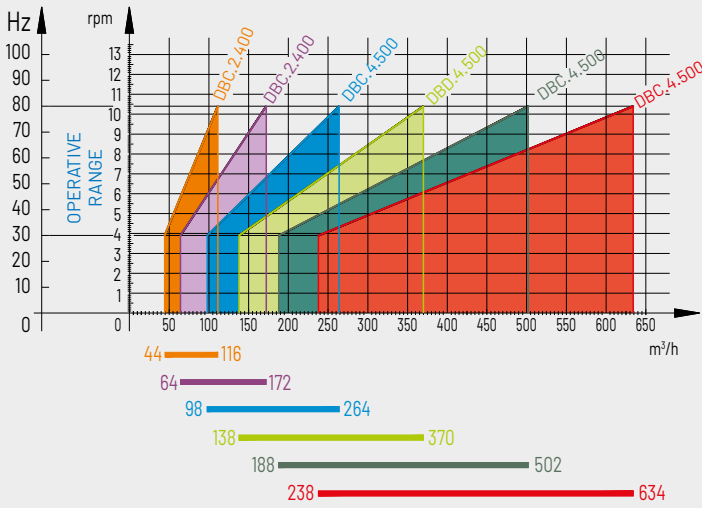
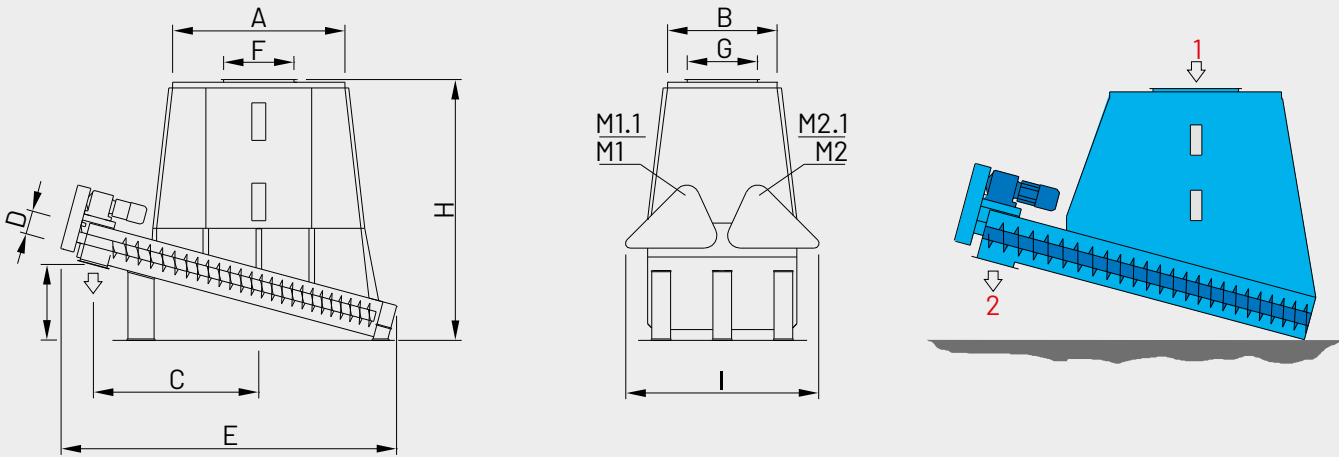

1 = FEEDING  
 2 = DISCHARGE  
 M1-M2 = SCREW ROTATION  
 M1.1-M2.1 = FAN FOR COOLING

## LIVE BOTTOM PITS - CLOSED TOP

FOR CHIPS ONLY & SPECIAL APPLICATION TO METER THE DRYER FEEDING BY CONVEYORS

MODEL	BIN CONTENT m³	THROUGHPUT m³/h	OVERALL DIMENSIONS mm										INSTALLED POWER kW**				WEIGHT APPROX. kg
			A	B	C	D	E	F	G	H	I	L	M1	M1.1	M2	M2.1	
DBC.2.400	5	SEE DIAGRAM	2310	975	2420	400	4470	2230	800	3300	995	1005	9,2	0,18	-	-	4300
DBC.4.500	30	SEE DIAGRAM	3845	2506	3340	500	7180	1500	1500	5570	4140	1615	11	0,18	11	0,18	19000
DBD.4.500*	30	SEE DIAGRAM	3600	1600	3685	500	8260	1200	1400	5390	2400	1405	45	0,27	45	0,27	13000
DBC.4.500	50	SEE DIAGRAM	3845	2506	3340	500	7180	1500	1500	5570	4140	1615	18,5	0,18	18,5	0,18	19000
DBC.4.500	60	SEE DIAGRAM	3845	2506	3340	500	7180	1500	1500	6570	4140	1615	22	0,18	22	0,18	20000

\*For dryer application

\*\*According to type of material

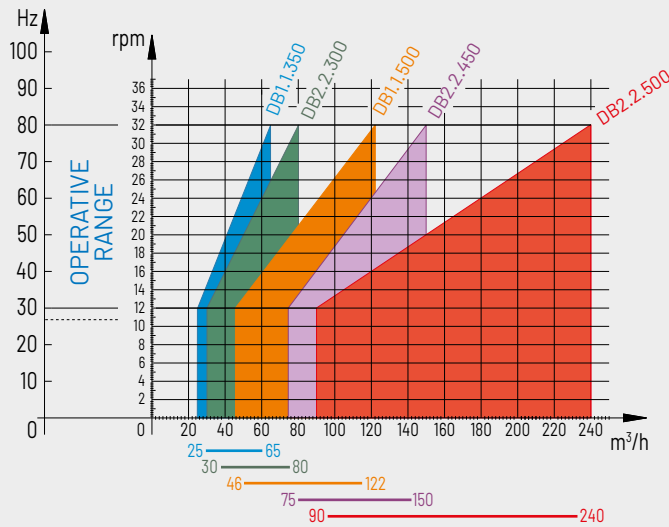
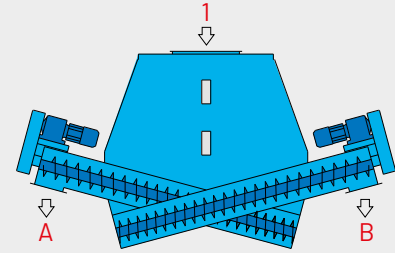
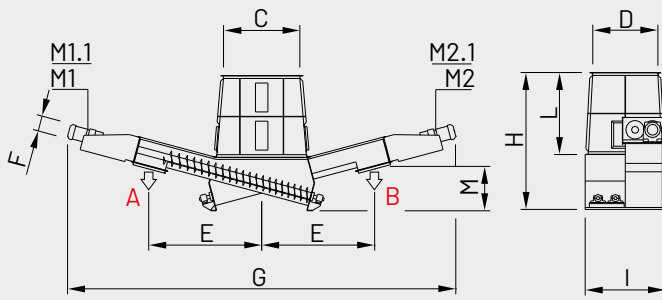

1 = FEEDING  
 A-B = DISCHARGE  
 M1-M2 = SCREW ROTATION  
 M1.1-M2.1 = FAN FOR COOLING

CAPACITY FOR EACH  
 FLOW A AND B

## LIVE BOTTOM PITS - CLOSED TOP WITH TWO EXTRACTATIONS

FOR CHIPS, SAWDUST, WET & DRY PARTICLES FEEDING BY CONVEYORS

07.07.B / 07.07.C

MODEL	BIN CONTENT m <sup>3</sup>	THROUGHPUT m <sup>3</sup> /h		OVERALL DIMENSIONS mm								
		A	B	C	D	E	F	G	H	I	L	M
DB1.1.350	2	25 - 65	25 - 65	1400	700	2075	350	5296	2411	930	1500	632
DB1.1.500	3	46 - 122	46 - 122	2000	900	3000	500	7392	2500	1370	1000	1150
DB2.2.300	3	30 - 80	30 - 80	1400	1200	2075	315	7335	2480	1472	1500	820
DB2.2.450	8	75 - 150	75 - 150	1600	1600	2606	450	6480	3280	2080	2000	1005
DB2.2.500	8	90 - 240	90 - 240	2000	1500	3296	500	7965	3430	2326	2000	1225

MODEL	INSTALLED POWER kW				WEIGHT APPROX. kg
	M1	M1.1	M2	M2.1	
DB1.1.350	4,0	0,08	4,0	0,08	2500
DB1.1.500	11,0	0,18	11,0	0,18	4000
	9,2	0,18	9,2	0,18	
DB2.2.300	5,5	0,08	5,5	0,08	4000
DB2.2.450	11	0,18	11	0,18	6500
DB2.2.500	9,2	0,18	9,2	0,18	8000
	11,0	0,18	11,0	0,18	

Solutions for different throughputs, layout arrangements and type of material are available upon request.

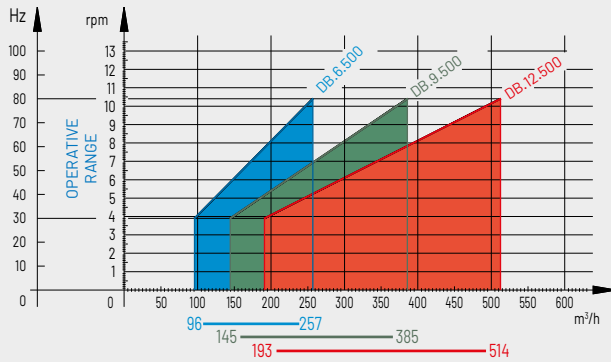
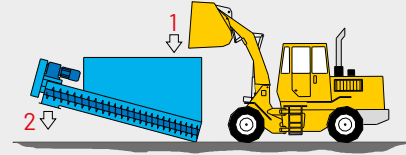
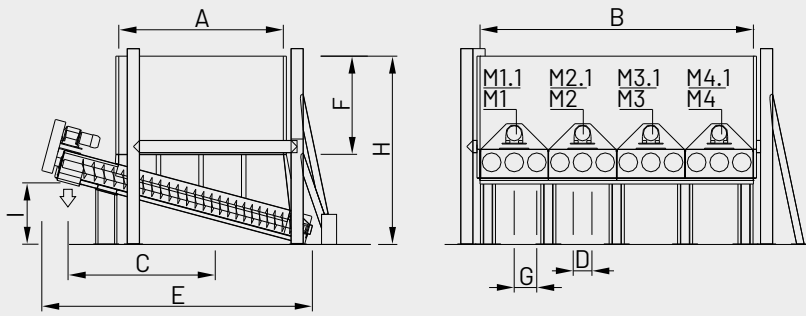

1 = FEEDING  
 2 = DISCHARGE  
 M1-M2-M3-M4 = SCREW ROTATION  
 M1.1-M2.1-M3.1-M4.1 = FAN FOR COOLING

## LIVE BOTTOM PITS - OPEN TOP

FOR CHIPS, SAWDUST, SHAVINGS WET & DRY PARTICLES FEEDING BY FRONT LOADER

MODEL	BIN CONTENT m <sup>3</sup>	THROUGH-PUT [30 - 80 Hz] m <sup>3</sup> /h	OVERALL DIMENSIONS mm									INSTALLED POWER kW								WEIGHT APPROX. kg
			A	B	C	D	E	F	G	H	I	M1	M1.1	M2	M2.1	M3	M3.1	M4	M4.1	
DB. 6.500	Chips 50	96-257	4372	4508	3719	500	7195	2608	750	5000	1540	11	0,18	11	0,18	-	-	-	-	19500
	Sawdust 40	96-257	4372	3632	3719	500	7195	2608	600	5000	1540	15	0,07	15	0,07	-	-	-	-	19500
DB. 9.500	Chips 75	145-385	4372	6762	3719	500	7195	2608	750	5000	1540	11	0,18	11	0,18	11	0,18	-	-	28500
	Sawdust 60	145-385	4372	5448	3719	500	7195	2608	600	5000	1540	15	0,07	15	0,07	15	0,07	-	-	28500
DB. 12.500	Chips 100	193-514	4372	9016	3719	500	7195	2608	750	5000	1540	11	0,18	11	0,18	11	0,18	11	0,18	37500
	Sawdust 80	193-514	4372	7264	3719	500	7195	2608	600	5000	1540	15	0,07	15	0,07	15	0,07	15	0,07	37500