

FERROUS METALS REMOVERS  
**MAGNETIC DRUMS – MD**

FOR CHIPS, SAWDUST AND PARTICLES



#### TECHNICAL FEATURES

- Strong family of magnetic drums fitted with bearings and supports
- Drive system
- Assembled unit complete of containment box.

#### BENEFITS

- High efficiency and reliability
- Removal of ferrous pollutants from chips, sawdust, particles, etc.
- Simple installation
- Very low maintenance.

#### BEST IN CLASS FOR:

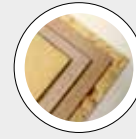

WOOD BASED PANELS:  
 MDF/HDF  
 PB/SPB  
 INSULATION BOARDS

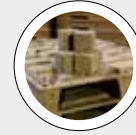

PRESSED WOOD PACKAGING:  
 PALLET BLOCKS



PELLETS & ENERGY:  
 WOOD PELLETS AND  
 BLACK PELLETS  
 LIME

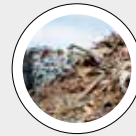

WOOD RECYCLING AND  
 WASTE TREATMENT:  
 WASTE

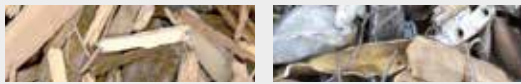
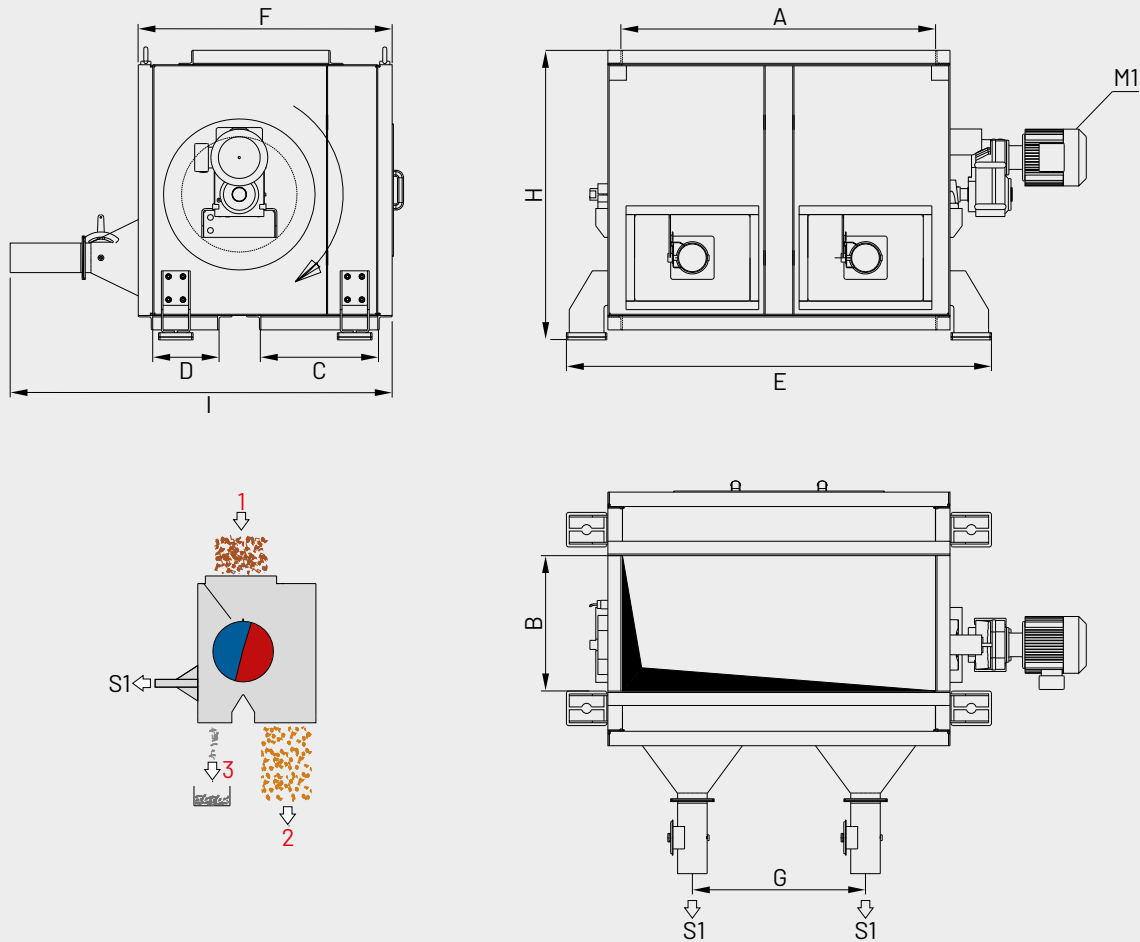

2

3

MODEL	OVERALL DIMENSIONS mm								
	A	B	C	D	E	F	G	H	I
MD.300x700 MRD	690	380	305	170	1068	725	-	750	1160
MD.400x700 MRD	690	470	405	225	1068	880	-	1005	1319
MD.400x1000 MRD	1085	470	405	225	1473	880	600	1005	1319
MD.500x1000 MRD	1185	600	505	280	1593	1035	700	1260	1479
MD.600x1000 MRD	1285	700	555	330	1713	1190	800	1360	1638
MD.400x1500 MRD	1585	470	405	225	1973	880	1000	1005	1319
MD.500x1500 MRD	1785	600	505	280	2193	1035	1050	1260	1479
MD.600x1500 MRD	1785	700	555	330	2193	1190	1050	1360	1638
MD.400x2200 MRD	2012	470	405	225	2392	880	655	1005	1319
MD.500x2200 MRD	2385	600	505	280	2793	1035	700	1260	1479
MD.600x2200 MRD	2385	700	555	330	2793	1190	630	1360	1638

MODEL	CAPACITY BULK CHIPS m³/h	INSTALLED POWER kW		SUCTION S1		WEIGHT APPROX. kg
		M1	PCS	PCS	SUCTION m³/h	
MD.300x700 MRD	60	1,1	1	1	1 x 800	600
MD.400x700 MRD	75	1,1	1	1	1 x 800	700
MD.400x1000 MRD	100	1,1	2	2	2 x 800	750
MD.500x1000 MRD	125	1,1	2	2	2 x 800	950
MD.600x1000 MRD	140	1,5	2	2	2 x 800	1150
MD.400x1500 MRD	155	1,5	2	2	2 x 800	835
MD.500x1500 MRD	185	1,5	2	2	2 x 800	935
MD.600x1500 MRD	200	1,5	2	2	2 x 800	1035
MD.400x2200 MRD	230	1,5	3	3	3 x 800	1300
MD.500x2200 MRD	270	1,5	3	3	3 x 800	1750
MD.600x2200 MRD	330	1,5	3	3	3 x 800	2450