

OSCILLATING SCREENS

**SCREENS****TECHNICAL FEATURES**

- Robust and rigid supporting pyramids • High precision kinematics • Excellent elastic suspensions • High tech screening boxes assembled with high-quality materials and made with special tried and tested procedures • 1-2-4 Stage screens • 1-4 Screening decks per stage • 2-5 Fractions available • Stainless steel sieves and frames • Auto-cleaning system based on bouncing balls • Fire-extinguishing system • Explosion vents • Extensive eccentric oscillation • Perfect balancing!

**BENEFITS**

- Perfect-absolute classification of any fraction • Quick and easy replacement of the screening frames • Unbeatable performance, efficiency and reliability • 36 months mechanical warranty!

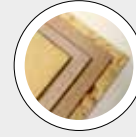
**BEST IN CLASS FOR:**

WOOD BASED PANELS:  
MDF/HDF  
PB/SPB  
OSB/LSB/FOSB

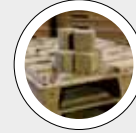

PRESSED WOOD PACKAGING:  
PALLET BLOCKS



PELLETS & ENERGY:  
WOOD PELLETS AND  
BLACK PELLETS  
LIME

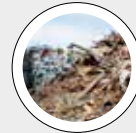

WOOD RECYCLING AND  
WASTE TREATMENT:  
WASTE

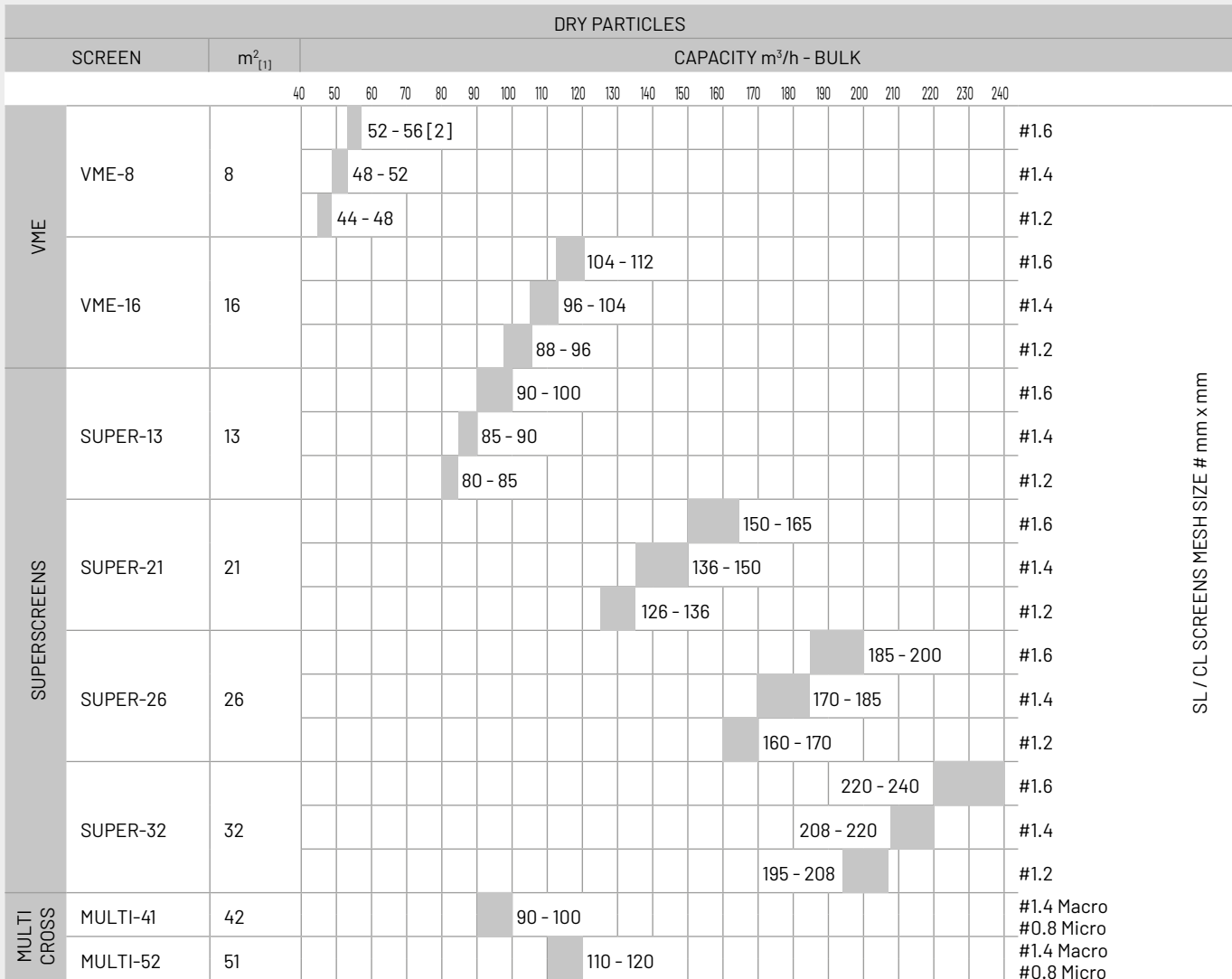
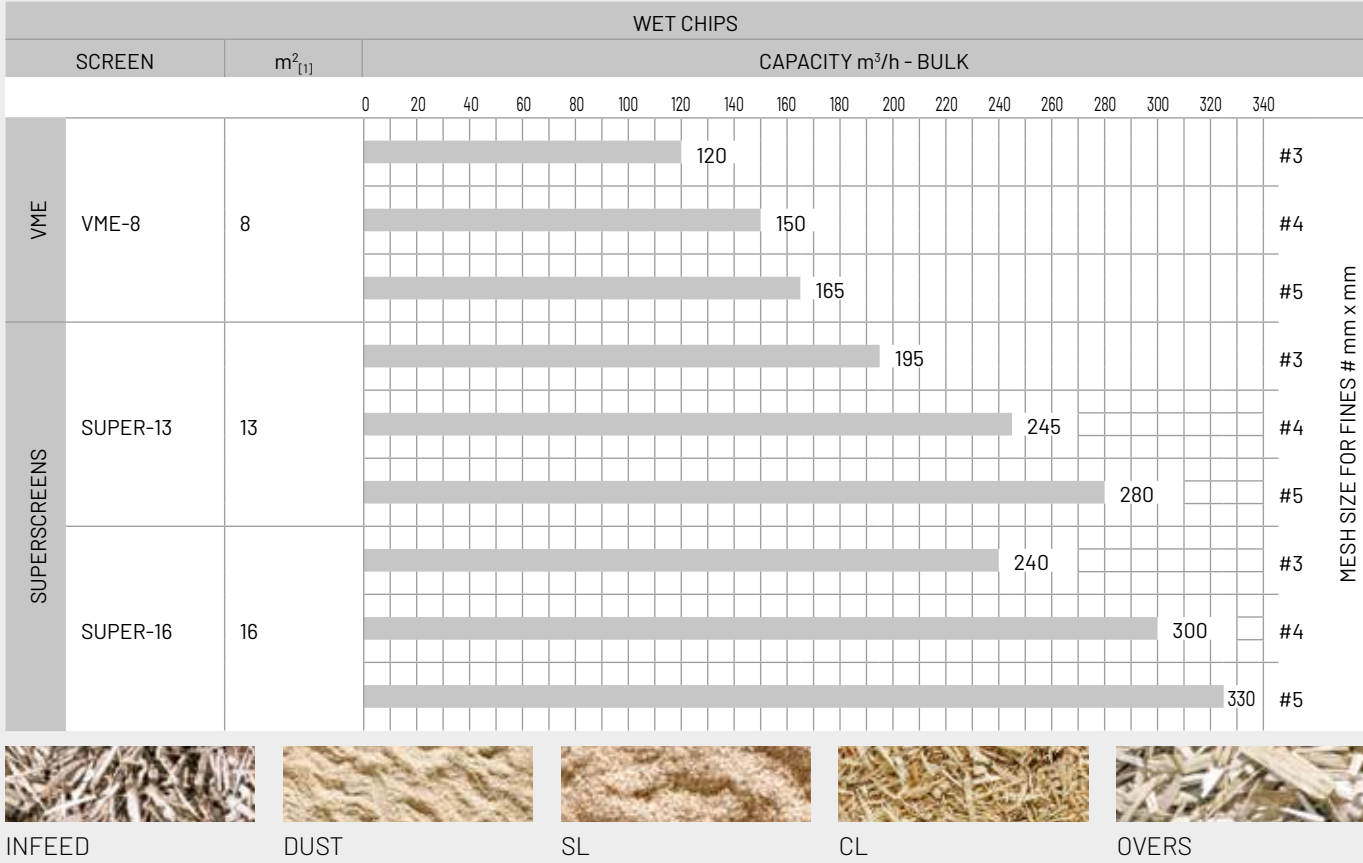

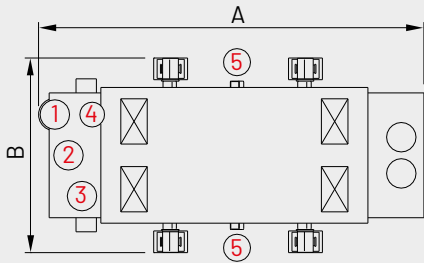
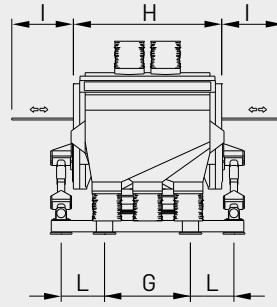
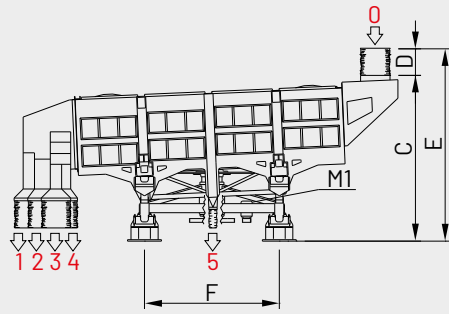

FOR DRY PARTICLES

**2 Double Decks**

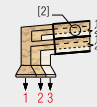

3 Fractions  
 SUPERSCREEN-DP-2P-21-EJ-...  
 SUPERSCREEN-DP-2P-26-EJ-...  
 SUPERSCREEN-DP-2P-32-EJ-...

**3 Double Decks**

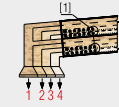

4 Fractions  
 SUPERSCREEN-DP-3P-21-EJ-...  
 SUPERSCREEN-DP-3P-26-EJ-...  
 SUPERSCREEN-DP-3P-32-EJ-...

**3 Double Decks**

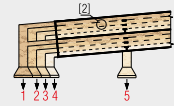

5 Fractions [option]  
 SUPERSCREEN-DP-3P/5-21-EJ-...  
 SUPERSCREEN-DP-3P/5-26-EJ-...  
 SUPERSCREEN-DP-3P/5-32-EJ-...

**4 Double Decks**

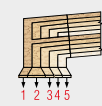

5 Fractions  
 SUPERSCREEN-DP-4P-26-EJ-...

O = FEEDING  
 1...5 = FRACTIONS

M1 = SCREENING  
 BOX MOVEMENT

[1] AC: Auto-cleaning ball-bouncing system for screens available for all decks  
 [2] A wide range of mesh sizes are available for any screening needs

# SUPERSCREEN 21-26-32

2-STAGE SCREENS - 21-26-32 m<sup>2</sup> EACH DOUBLE DECK

MODEL	OVERALL DIMENSIONS mm										INSTALLED POWER kW	WEIGHT APPROX. kg
	A	B	C	D	E	F	G	H	I	L		
SUPERSCREEN DP-2P-21-EJ	8440	3860	3660	600	4260	2980	1900	2560	1250	740	11,0	15000
SUPERSCREEN DP-3P-21-EJ	8485	3860	3660	600	4260	2980	1900	2560	1250	740	11,0	15300
SUPERSCREEN DP-3P/5-21-EJ	8485	3860	3660	600	4260	2980	1900	2560	1250	740	11,0	15300
SUPERSCREEN DP-2P-26-EJ	8440	4300	3660	600	4260	2980	1900	3000	1500	960	15,0	16600
SUPERSCREEN DP-3P-26-EJ	8520	4300	3660	600	4260	2980	1900	3000	1500	960	15,0	17100
SUPERSCREEN DP-3P/5-26-EJ	8520	4300	3660	600	4260	2980	1900	3000	1500	960	15,0	17600
SUPERSCREEN DP-4P-26-EJ	8620	4300	3780	600	4380	2980	1900	3000	1500	960	15,0	17600
SUPERSCREEN DP-2P-32-EJ	8450	5050	3660	600	4260	2980	1900	3750	1875	1335	18,5	17400
SUPERSCREEN DP-3P-32-EJ	8640	5050	3660	600	4260	2980	1900	3750	1875	1335	18,5	18000
SUPERSCREEN DP-3P/5-32-EJ	8640	5050	3660	600	4260	2980	1900	3750	1875	1335	18,5	18000