



• PB - MDF - PALLET BLOCK - PRESSED PALLET - WASTE - LIME

PAL

**IMAL
PAL
GROUP**

CRUSHERS

TIGER-K

FROM URBAN FOREST TO READY CHIPS

TECHNICAL FEATURES

• U-feeder based on vibrating channel or long chain-plate conveyor • Swivelling introduction head with roller • High speed rotor equipped with very strong hammers-knives • Possibility to change the direction of operation rotor as needed • Digesting chamber equipped with openable inspection gates and inner wearproof protections • Front flaps to reject indigestible materials such as large metallic contaminants, etc. • Very big strong hammers • Outfeed screen to control the size of crushed chips.

BENEFITS

• Easy digestion of all urban forest material, bulky or pre-crushed • Easy digestion of pollutants such as minerals, stones, plastics, glass, etc. • Elimination of bigger and tougher heavy pollutants • Very low specific energy consumption and maintenance.

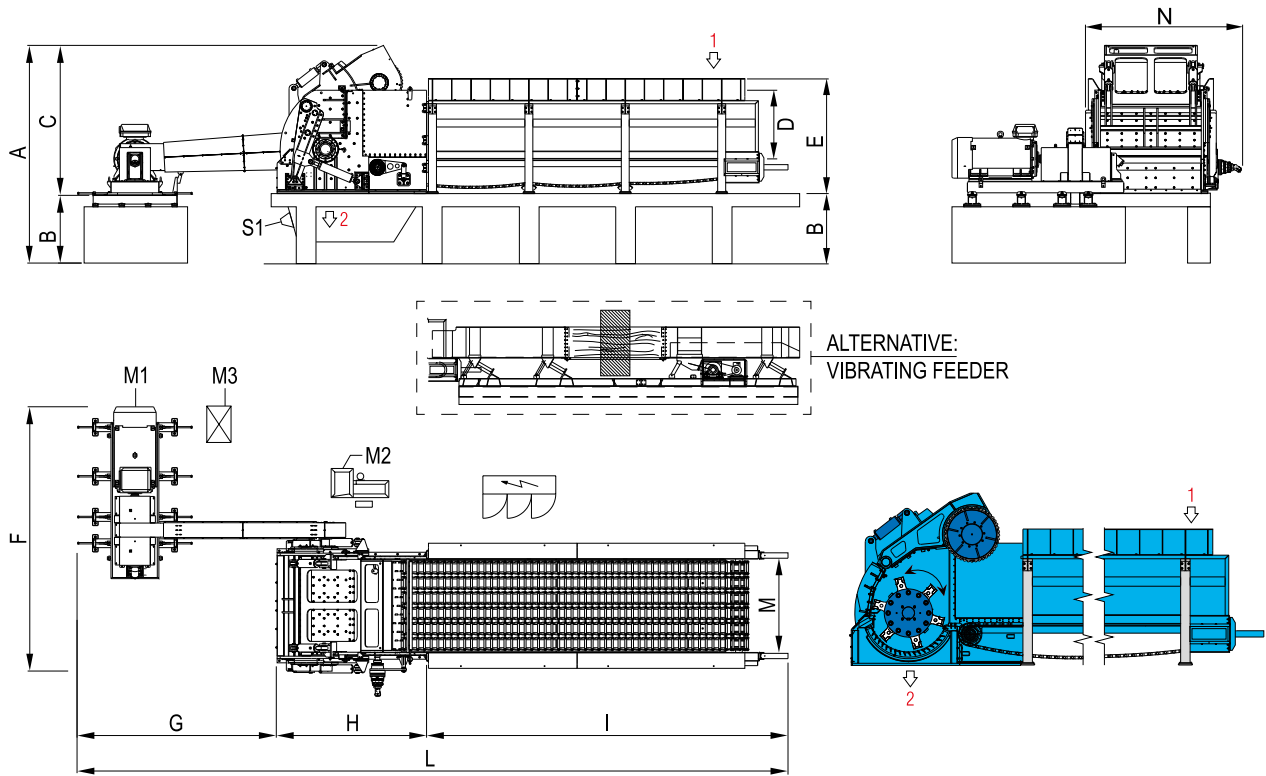

1 = BULKY RECYCLING
2 = CHIPS

M1 = MAIN MOTOR
M2 = HYDRAULIC SYSTEM

M3 = HYDRAULIC POWER UNIT FOR
MAIN MOTOR STARTING

MODEL	OVERALL DIMENSIONS mm										
	A	B	C	D	E	F	*G	H	I	L	M
TIGER-K 210-110	5367	2000	3367	1592	2610	6500	4528	3440	8167	16135	2100

*Variable according to motor size

MODEL	INLET SECTION		ROTOR DIAMETER mm	CAPACITY** t/h	INSTALLED POWER kW			WEIGHT APPROX. kg TOTAL
	WIDTH mm	HEIGHT mm			M1**	M2	M3	
TIGER-K 210-110	2100	1100	1400	40-65	1000	55	75	70000

**According to type, bulk density and moisture content of material to crush

MODEL	EXHAUST SUCTION S1		
	SUCTION m ³ /h	AIR SPEED m/s	SUCTION PRESSURE Pa
TIGER-K 210-110	30000-50000	29	1000