



• MDF • PB • PALLET BLOCKS • PELLETS • WASTE • LIME



IMAL
PAL
GROUP

AIR SIFTERS

AIRGRADER – SINGLE MACHINES

TECHNICAL FEATURES

• Classifying chamber complete with: infeed system (from model 3.1M) – inclined fluidizing screen – zigzag channels – suction hopper connected to the cyclone – outfeed device for rejected particles – discharge system for heavy pollutants • Fan • Cyclone for accepted particles • AF - Fire extinguishing system • AE - Explosion protection system.

BENEFITS

• High efficiency in classification • The turbulence generated by the zigzag channels ensures the thick-large (jumbo) particles to drop (that are improperly sucked and classified as accepts by other selectors) • Selection limit freely adjustable • Excellent removal of heavy pollutants • Highly reliable • Low maintenance.

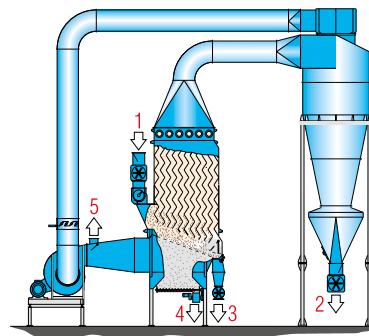
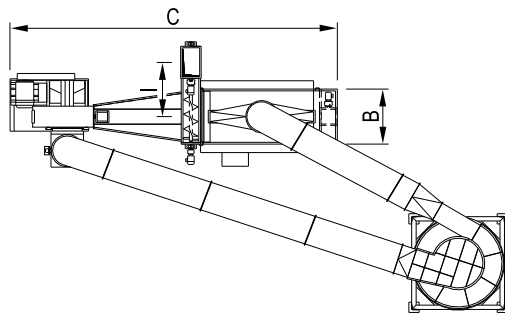
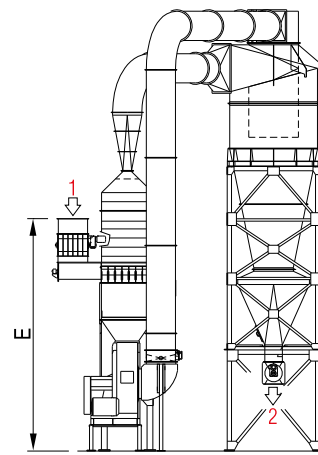
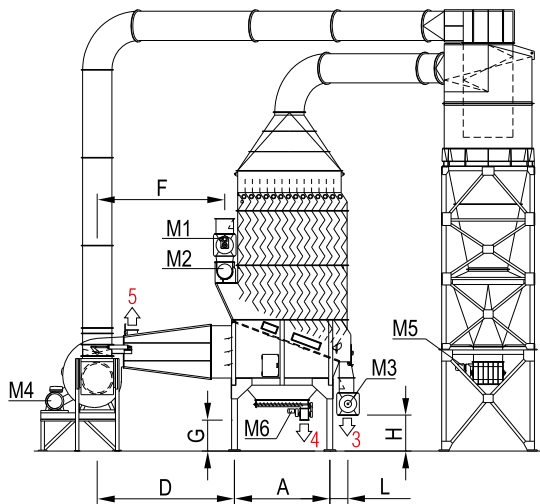

- 1= POLLUTED PARTICLES
- 2= ACCEPTS, CLEANED THIN PARTICLES
- 3= REJECTS, THICK PARTICLES
- 4= SAND / HEAVY POLLUTANTS
- 5= EXHAUST AIR

- M1= FEEDING SCREW
- M2= ROTARY VALVE IN
- M3= ROTARY VALVE REJECT EXTRACTION

- M4= FAN DRIVE
- M5= ROTARY VALVE OUT
- M6= ROTARY VALVE SAND EXTRACTION



2

3

4

MODEL	OVERALL DIMENSIONS mm									
	A	B	C	D	E	F	G	H	I	L
1,6 M	1730	806	7398	3200	5850	2949	1000	1382	-	550
2,0 M	2260	806	8098	3350	6934	3010	1200	1315	-	570
2,5 M	2290	1006	8046	3351	6934	3011	1200	1220	-	540
3,1 M	2200	1256	8455	3552	7739	3007	1200	1365	1622	600
3,5 M	2200	1406	8785	3650	7714	3180	1200	1380	1368	600
4,0 M	2450	1556	9087	3700	7644	3237	1200	1361	1372	602
4,5 M	2450	1626	9267	3800	7672	3305	1200	1361	1487	602
5,3 M	3258	1506	10043	3743	8217	3258	1200	1426	1457	570
6,2 M	3258	1756	10043	3800	8172	3265	1200	1326	1922	570
7,5 M	3258	2106	10084	3791	8172	3265	1134	1200	1774	575
8,3 M	3717	2166	10548	3889	8507	3304	1200	1643	1775	616
9,0 M	3717	2260	10548	3800	8507	3265	1200	1622	1775	616
10,0 M	3763	2620	12155	4765	8694	4185	1007	1326	2477	570
12,5 M	3763	3220	12155	4765	9453	4190	1020	1330	2777	664

Cyclone and pipe have to be sized and located according to the process data for processed material and outfeed position

MODEL	CAPACITY t/h		INSTALLED POWER kW						EXHAUST AIR m ³ /h	WEIGHT* APPROX. kg
	SAWDUST/SHAVINGS	OVERSIZE DRY PARTICLES	M1	M2	M3	M4	M5	M6		
1,6 M	5,8	5,8	-	1,5	1,5	Information available according to processed material and cyclone distance.	1,5	0,75	Information available according to processed material.	7500
2,0 M	7,2	7,2	-	1,5	1,5		1,5	0,75		8000
2,5 M	9,0	9,0	-	3,0	1,5		3,0	0,75		9000
3,1 M	11,2	11,2	3,0	4,0	1,5		4,0	0,75		10000
3,5 M	12,6	12,6	4,0	4,0	1,5		4,0	0,75		10500
4,0 M	14,4	14,4	4,0	4,0	1,5		4,0	0,75		11500
4,5 M	16,2	16,2	4,0	4,0	1,5		4,0	0,75		13000
5,3 M	19,1	19,1	7,5	5,5	1,5		5,5	0,75		14000
6,2 M	22,3	22,3	7,5	5,5	3,0		5,5	0,75		15000
7,5 M	27,0	27,0	7,5	5,5	3,0		5,5	0,75		16000
8,3 M	29,9	29,9	9,2	5,5	3,0		5,5	0,75		16700
9,0 M	32,4	32,4	9,2	5,5	3,0		5,5	0,75		18100
10,0 M	36,0	36,0	9,2	5,5	3,0		5,5	0,75		19200
12,5 M	45	45	9,2	5,5	3		5,5	0,75		30400

*Weight without piping and cyclone