



• MDF • PB • OSB • INS. BOARD • PALLET BLOCKS • PELLETS • WASTE • LIME



IMAL
PAL
GROUP

CIRCULAR EXTRACTORS

HYDROMAT

TECHNICAL FEATURES

- Strong sliding scraper-extractor alternatively driven by hydraulic piston/s
- Piston/s housing box with seals to prevent material leakage
- Integrated power-pack to drive the hydraulic piston/s
- Progressively variable pitch screw/s for better accuracy
- Electronic level indicator for screw empty condition
- Supply of silo drawing only for local manufacturing
- Supply of complete silo and protections, including: bridge-breakers for cylindrical silos, when needed
- continuous level indicator, i.e. ultrasound system
- electromechanical levels for emergency (Top-minimum)
- AF - Fire extinguishing system
- AE - Explosion vents.

BENEFITS

- Versatile destorage-dosing system for wet or dry fractioned materials i.e. chips, sawdust, shavings, particles, dust, etc.
- Wide range of extraction capacity achieved by controlling the dosing screws with frequency converters
- High dosing accuracy from progressively variable pitch screws
- Reliable control of silo levels
- Simple and cheap system
- High reliability
- Very low maintenance cost.

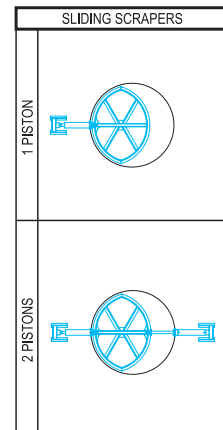
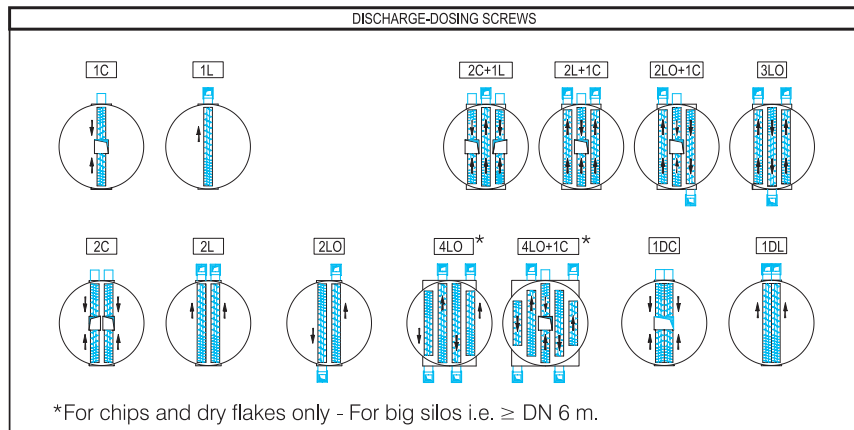
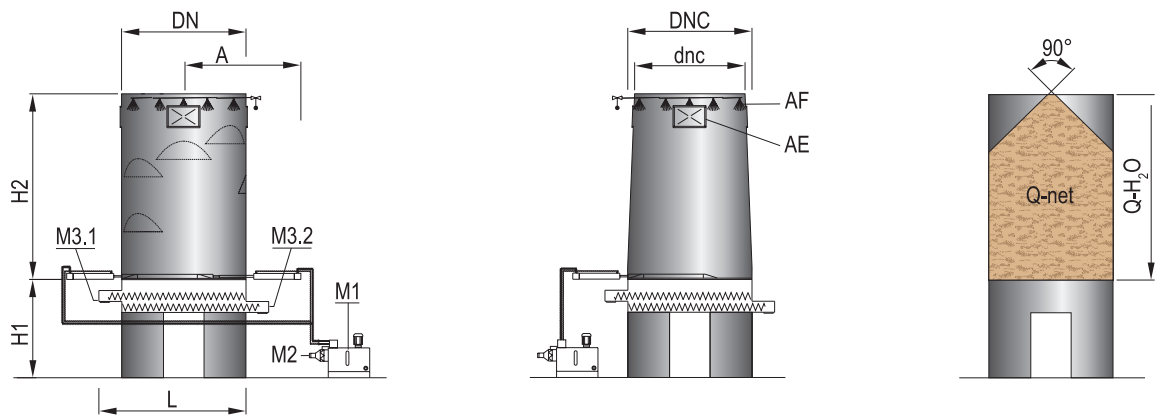

FOR DRY MATERIAL ONLY
 AF = FIRE-EXTINGUISHING SYSTEM
 AE = EXPLOSION VENTS

M1 = HYDRAULIC POWER-PACK
 M2 = HEAT EXCHANGER

M3.1 = EXTRACTING SCREW
 M3.2 = EXTRACTING SCREW

MODEL	THROUGHPUT m ³ /h	OVERALL DIMENSIONS mm							SILO CONTENT m ³ UP TO			INSTALLED POWER kW				WEIGHT APPROX. kg
		DN	DNC	dnc	A	L	H1	H2 UP TO	Q-H ₂ O	Q-net	M1	M2	M3.1	M3.2		
HYD.4,0-1P	Wide range available, according to customer needs	4000	-	-	4200	5500	According to layout requirement	9000	110	95	According to Material throughput & Characteristics					2300
HYD.4,5-1P		4500	-	-	4450	6000		10000	160	135						2400
HYD.5,1-1P		-	5100	4300	5350	6500		10000	175	155						3300
HYD.5,1-2P		-	5100	4300	5350	6500		10000	175	155						3500
HYD.5,5-1P		5500	-	-	5550	7000		12000	285	245						5300
HYD.5,5-2P		5500	-	-	5550	7000		12000	285	245						5500
HYD.6,0-1P		6000	-	-	5800	7500		15000	425	370						6000
HYD.6,0-2P		6000	-	-	5800	7500		15000	425	370						6300
HYD.6,5-1P		6500	-	-	6250	8000		16000	530	460						6400
HYD.6,5-2P		6500	-	-	6250	8000		16000	530	460						6700
HYD.7,0-2P		7000	-	-	6500	8500		18000	690	600						7000