



• MDF • PB • OSB • INS. BOARD • PALLET BLOCKS • PELLETS • WASTE • LIME



IMAL
PAL
GROUP

METERING BINS

BBT

FOR WET PARTICLES

TECHNICAL FEATURES

• Volumetric dosing of wet and dry particles for dosing bin only • Gravimetric metering of wet and dry particles for dosing bin & belt scale • Excellent dosing-metering solution for dryers, process mills and blenders.

Dosing Bin

• Strong-modular bin provided with: inspection windows – electronic levels for filling control – fire-extinguishing system for dry materials – explosion protection system for dry materials • Front scalping-fluidizing rolls • Drive systems • Pre-wiring of all electrical fittings up to a junction box • Weighing belt with load cell • Tensioning-centering system for the belt • Drive system • Calibration chain • Microprocessor including all functions for electronic calibration • Accuracy for wet particles better than +/- 2,5% relating to instant flow • Accuracy for dry flakes better than +/- 2,0% relating to instant flow • Continuous-constant feeding of material with constant running of dosing bin • Employment range from 10 to 100% of nominal throughput.

Belt scale

• Weighing belt with load cell • Tensioning-centering system for the belt • Drive system • Calibration chain • Microprocessor including all functions for electronic calibration.

BENEFITS

• Perfect mixing of particle flow from scalping rolls milling the front section • High-stable volumetric accuracy • Very high weighing-metering accuracy • Accuracy is related to instant flow and not to the full scale value as in conventional systems • High efficiency and reliability • Low maintenance • Accuracy from dosing bin + belt scale higher than +/- 0,5% relating to instant flow! • Employment range from 10 to 100% of full scale value • Full scale value is freely settable • Easy testing by calibrating chain.

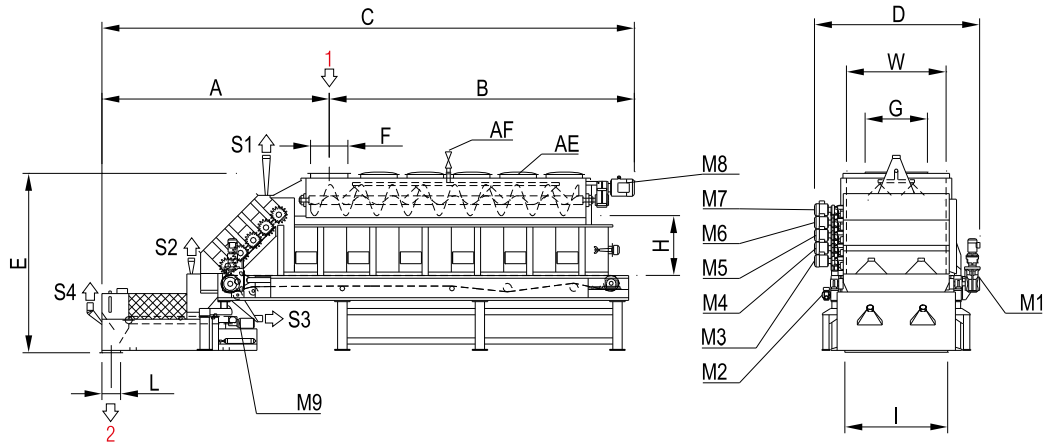

- 1= FEEDING
- 2= DISCHARGE
- S1-S2-S3-S4= SUCTION
- M1= FEEDING BELT ROTATION
- M2= CLEANING DEVICE COMAND
- M3-M4-M5-M6-M7= FRONT MILL ROTATION
- M8= LEVELLING SCREW ROTATION
- M9= DOSING BELT DRIVE

FOR DRY MATERIAL:
 AF= FIRE-EXTINGUISHING SYSTEM
 AE= EXPLOSION VENTS

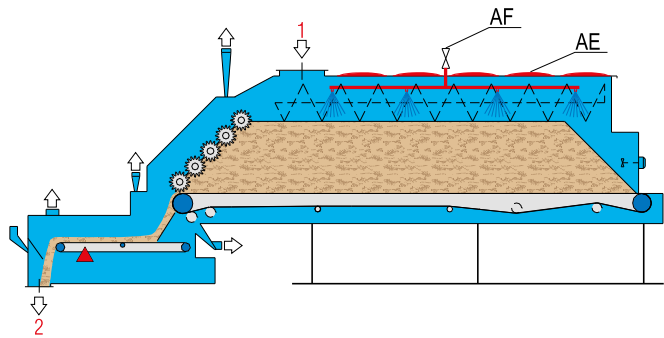

MODEL	OVERALL DIMENSIONS mm									USEFUL SECTION mm	
	A	B	C	D	E	F	G	I	L	H	W
BBT 24	3700	4810	8660	2300	2840	600	750	1250	300	1000	1200
BBT 36	3700	4810	8660	2700	2840	600	1150	1650	300	950	1600
BBT 60-20	4600	6005	10755	3190	3735	600	1550	1650	300	1500	2000
BBT 60-30	4600	8980	12160	3190	3735	600	1550	1650	300	1500	2000

MODEL	CAPACITY BULK MATERIAL			BIN VOLUME m ³	INSTALLED POWER kW					
	m ³ /h	t/h	RATIO		M1*	M1.1	M2	M3...M7	M8	M9
BBT 24	240	According to bulk density	1:6	6	0,55	0,07	0,37	1,10	2 x 2,20	0,55
BBT 36	360			8	0,75	0,07	0,37	1,10	4 x 2,20	0,55
BBT 60-20	600			20	1,50	0,07	0,37	1,50	4 x 3,00	0,75
BBT 60-30	600			30	1,50	0,07	0,37	1,50	4 x 3,00	0,75

*For SL - CL

MODEL	COM-PRESSED AIR Nm ³ /h	AF** H ₂ O - 6 bar		SUCTION										WEIGHT APPROX. kg	
				THROUGHPUT WET MATERIAL m ³ /h				THROUGHPUT DRY MATERIAL m ³ /h				AIR SPEED m/s	SUCTION PRESSURE Pa		
				DN	l/min	S1	S2	S3	S4	S1	S2				
BBT 24	0,05	50 G 2"	560	1 x 1780	2 x 800	1 x 800	2 x 800	1 x 1600	2 x 710	1 x 710	2 x 710	29	200	6500	900
BBT 36				1 x 1780	2 x 800	1 x 800	2 x 800	1 x 1600	2 x 710	1 x 710	2 x 710	29	200	8000	1200
BBT 60-20				2 x 1780	2 x 800	1 x 1780	2 x 800	2 x 1600	2 x 710	1 x 1600	2 x 710	29	200	14000	1200
BBT 60-30				2 x 1780	2 x 800	2 x 1780	2 x 800	2 x 1600	2 x 710	1 x 1600	2 x 710	29	200	16800	1200

**AF = Fire-extinguishing system (Option for dry materials)