



• PB • OSB • MDF



COMPUTERIZED COMPONENT DOSING SYSTEM

WINDOSER-PLCDOSER

FULLY AUTOMATED CHEMICAL DOSING OPERATIONS

IMAL's WINDOSER-PLCDOSER flexible, computer controlled dosing system, is able to dose each component separately or perform batch operations and dose glue mixtures. The components are dosed by means of a PLC driven motor pump and may be controlled by a flow meter or a load cell (hopper scale). All the components are mixed together in a static mixer just before being added to the wood. The system also manages the consumption data report for each component, fully exploiting the filling and storage capacities which the system has to offer. It is also possible to print a wide range of data.

MAIN FEATURES

- User-friendly software
- Clear and modern graphics with simple and intuitive controls
- Powerful calculation sheets to aid the technologist with the recipes
- May be used with most of the SCADA programmes available today (IMAL-WINSCADA, INTOUCH, RSVIEW)
- Modularity and open to future expansion
- Available with SIEMENS PLC or Allen-Bradley PLC
- Incorporated database to store all the alarms and consumptions report, available in several formats, by day, month, and year
- System may be linked up with other equipment for data exchange, and is fully compatible with the industrial networks used for automation today, such as ETHERNET, PROFIBUS, DEVICE NET, CONTROL NET, etc.
- The dosing system can run with signals from the screw feeders (MDF only), from the main scale, from the forming line scale
- Suitable for all kinds of blending processes and boards (particleboard, MDF, OSB)
- Various settings possible for component quantities
- Supervision of all the phases from component preparation through to dosing.

ADVANTAGES

- Monitoring of the alarm status
- Absolute simplicity in the monitoring of the plant status
- Less time wasted for production programming and eliminating errors
- Better production control
- Dosing managed over several levels and layers
- Automatic control cuts down the time required for cleaning operations.

GLUE MIXTURE RECIPE TABS:

This page allows you to monitor and change the values of the archive recipe.



PRODUCTION CONTROL:

This page gives you the possibility of monitoring the real time production values.



SHOW SYNOPTIC:

Different synoptics are possible in Windoser. All the synoptics are completely configurable and use information available through the PLC program.

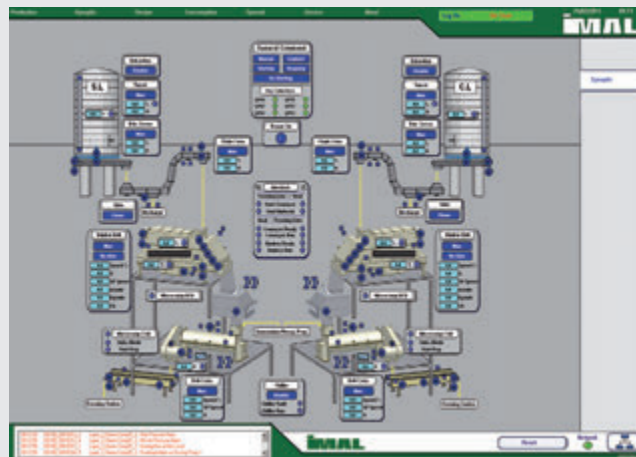
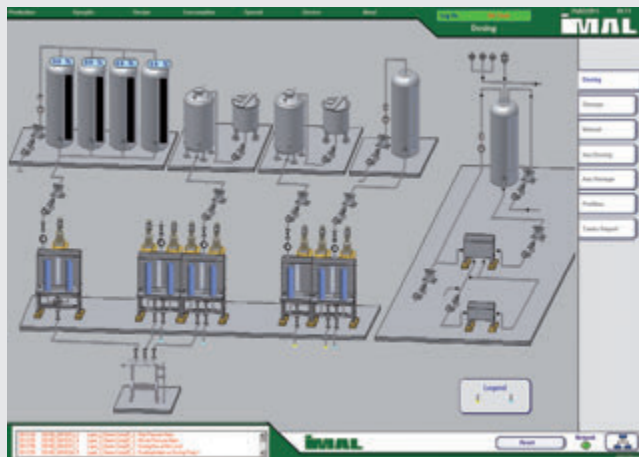

DOSING SYSTEM - TECHNICAL DATA

MANAGES	Up to 10 components per line
THROUGHPUTS	From 0.05 to 8000 kg/h
DIGITAL THROUGHPUT READING PRECISION	± 0.1 %
FORMULAS	Unlimited formulas
STORES CONSUMPTION FOR ANY PERIOD	Up to 1 year (standard)
CONTROL	Fully automatic
THE SYSTEM CONFIGURATION CAN BE APPLIED TO ANY KIND OF PLANT	

GRAVIMETRIC PREPARATION SYSTEM - TECHNICAL DATA

MANAGES	Up to 15 components per vessel (max 10 vessels)
CARRIES OUT PREPARATIONS	Of up to 2500 kg
MAX. CAPACITY	15000 kg/h
PREPARATION PRECISION	± 0.1 %
SERVES	Up to 9 lines
COMPLETELY CONTROLS	Unlimited formulas

SYSTEM CONFIGURATION

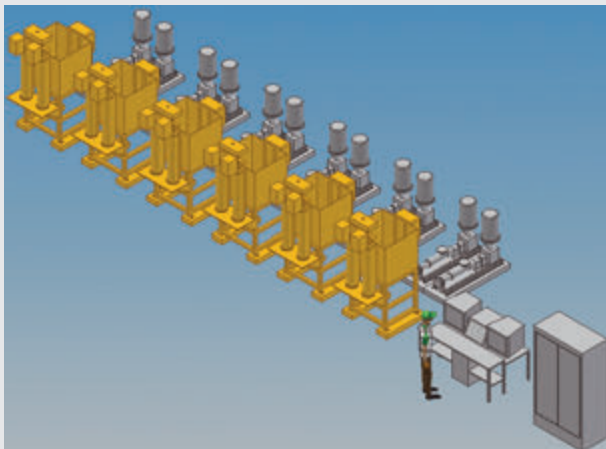
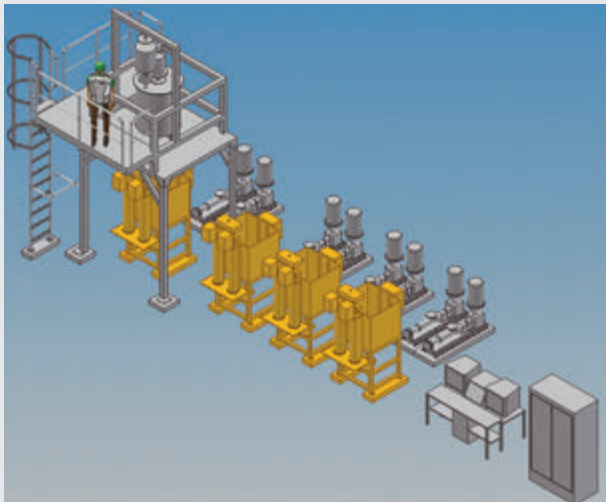
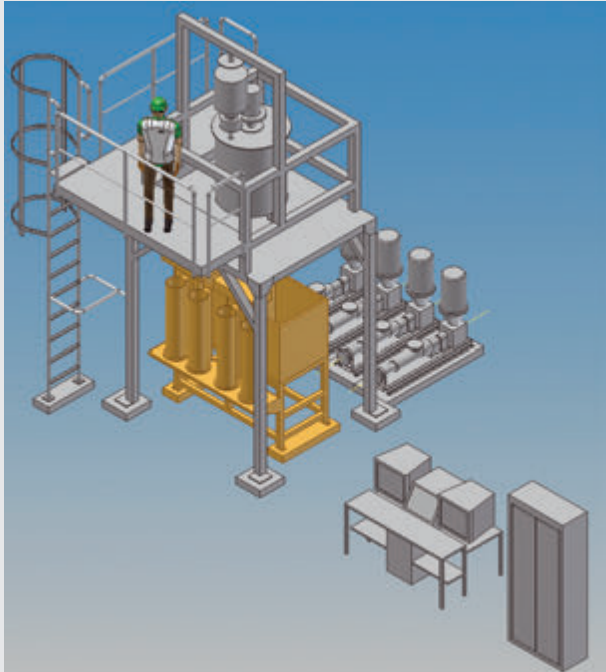

FOR PARTICLEBOARD LINES:

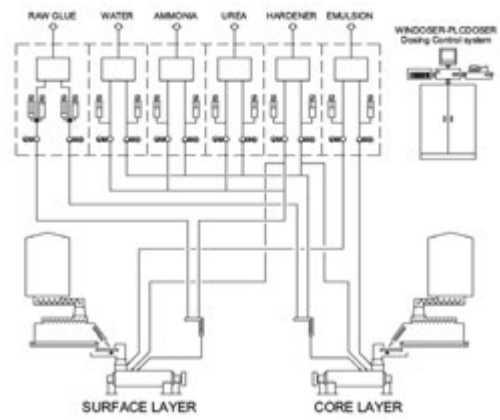
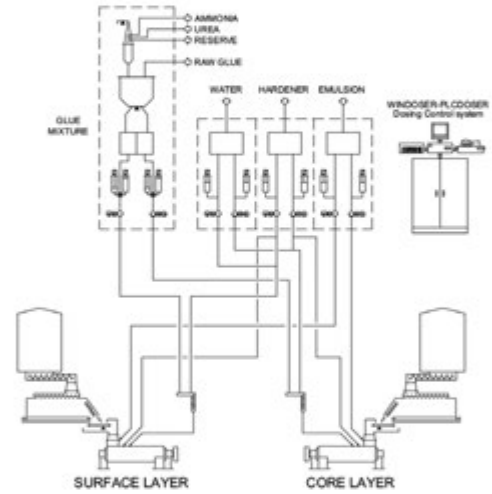
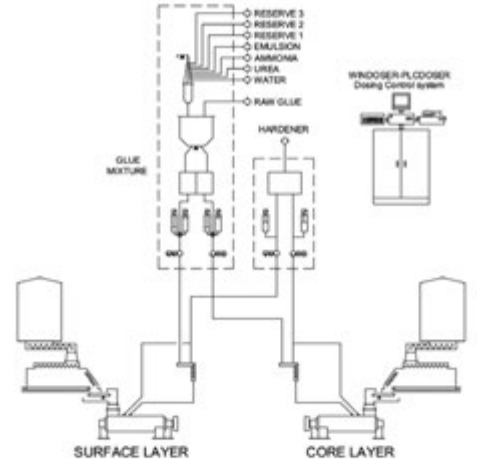

SYSTEM CONFIGURATION

FOR MDF LINES:

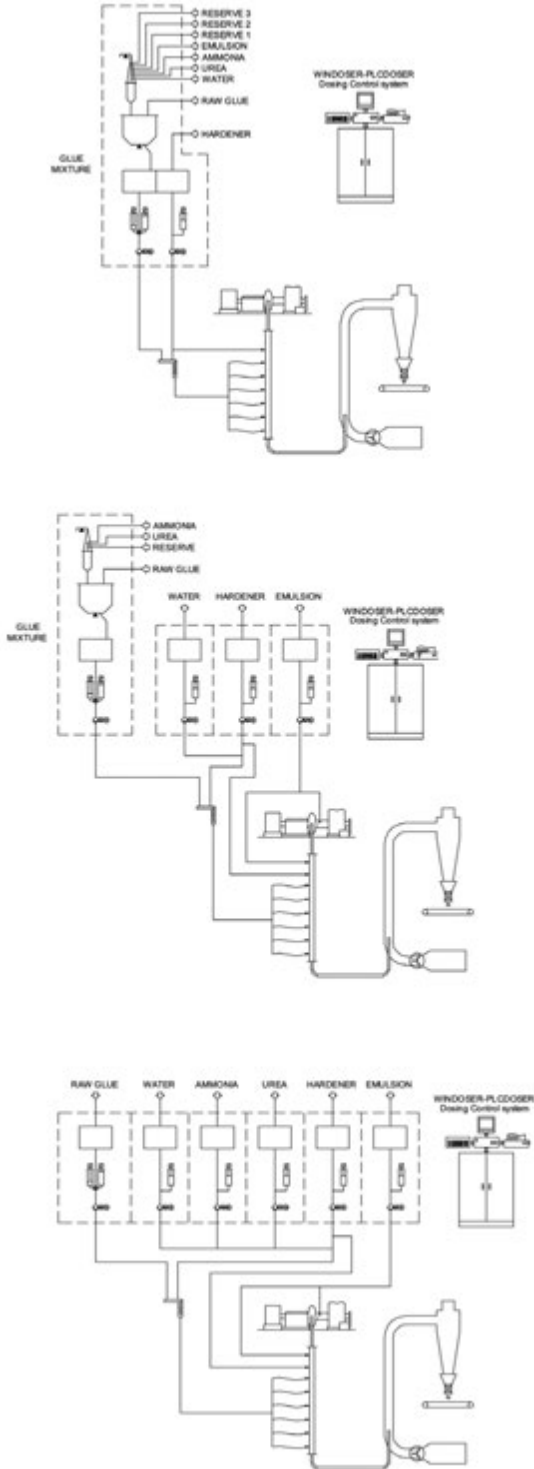

FOR OSB LINES:

